

**SEGA®**

# GALAXY FORCE

SUPER DELUXE TYPE

## OWNER'S MANUAL

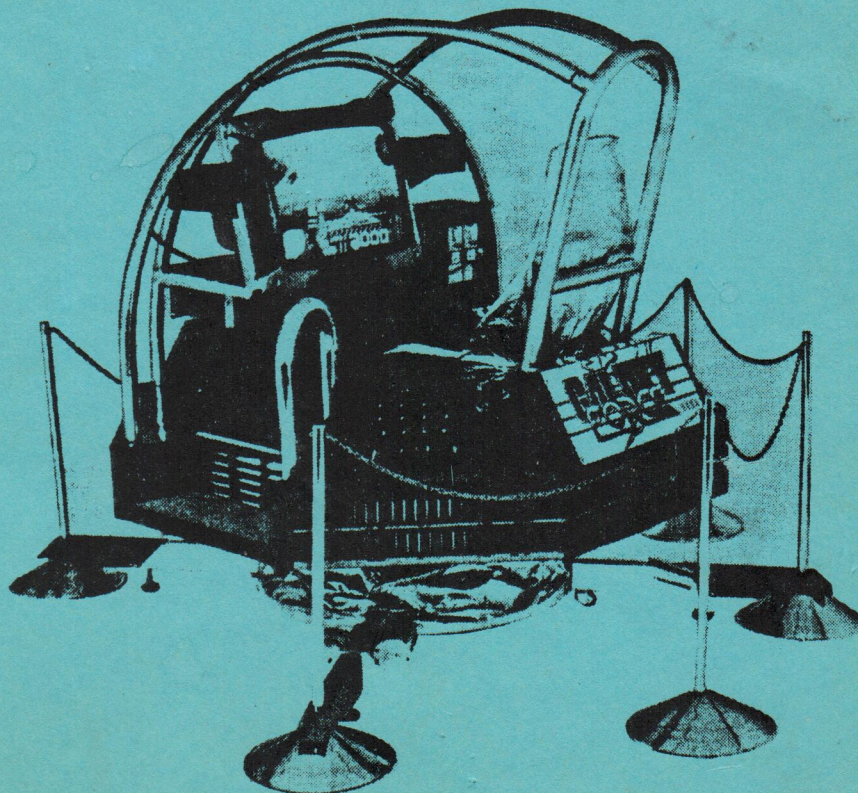

**SEGA ENTERPRISES, LTD.**



---

---

## TABLE OF CONTENTS

---

---

INTRODUCTION OF THE OWNER'S MANUAL .....	1
1. HANDLING PRECAUTIONS .....	1
2. PREVENTION OF COUNTERFEITING AND CONVERSION .....	2
3. PRECAUTIONS CONCERNING THE PLACE OF INSTALLATION .....	3
4. INSTALLATION PRECAUTIONS AND MOVING THE MACHINE .....	4
5. DISASSEMBLING .....	5 ~ 6
6. NAME OF PARTS .....	7
7. AC UNIT .....	8
8. CAUTIONS TO BE TAKEN WHEN TURNING THE POWER ON .....	9
9. ADJUSTING THE THROTTLE .....	10
10. ADJUSTING THE HANDLE UNIT .....	11
11. REMOVING THE MECHANISM UNIT .....	12 ~ 13
12. REPLACING THE BRAKE PAD .....	14
13. REMOVING THE MOTOR UNIT .....	15
14. REPLACING THE MOTOR BRUSHES .....	16
15. BANKING ADJUSTMENT .....	17 ~ 18
16. TURN ADJUSTMENT .....	19 ~ 20
17. ADJUSTING THE INFRARED SENSORS .....	21
18. REPLACING THE BILLBOARD LAMP .....	22
19. SELF-TEST .....	23 ~ 28
20. REMOVING THE I.C. BOARD (SHIELD BASE) .....	29
21. SERVICE SWITCHES .....	30
22. 26 INCH MONITOR .....	31
23. DIP SWITCH SETTING .....	32
24. EPROM/MASK ROM LOCATIONS .....	33
25. PARTS LIST .....	34 ~ 72
26. WIRING DIAGRAM .....	73 ~ 74

---

---

### SPECIFICATIONS

---

- |   |                    |  |
|---|--------------------|--|
| • | INSTALLATION SPACE | : 2700 mm (106.3 in) (L) × 2310 mm (91 in) (W) |
| • | HEIGHT             | : 1800 mm (70.9 in), 2010 mm (79 in) (MAX)     |
| • | WEIGHT             | : 400 kg (882 lbs.)                            |
| • | POWER              | : 460 W  |
| • | C.R.T              | : 26 INCH                                      |

#### NOTE :

Descriptions herein contained may be subject to improvement changes without notice.



## INTRODUCTION OF THE OWNER'S MANUAL

SEGA ENTERPRISES, LTD., supported by its high electronic technology of LSIs, microprocessors, etc., and a wealth of experience, has for more than 30 years been supplying various innovative and popular game machines to the world market. This OWNER'S manual is intended to provide detailed comments together with all the necessary information covering the operation in general of electronic assemblies, electromechanicals, servicing control, spare parts, etc. as regards the GALAXY FORCE, a new SEGA product. The manual is intended for those who have knowledge of electricity and technical expertise especially in ICs, CRTs, microprocessors, etc. Carefully read so as to acquire sufficient knowledge before working on the machine. Should there be a malfunction, non-technical personnel should under no circumstance touch the interior system.

### 1. HANDLING PRECAUTIONS

When installing or inspecting, be very careful of the following points and pay attention to ensure that the player can enjoy the game safely.

- Be sure to turn the power off before working on the machine.
- To insert or pull out the plug quickly is dangerous.
- It is necessary to make sure that the power cord or the grounding wire is not exposed on the road, etc. in a manner so as to be dangerous. Make sure that grounding connections are made safely at the position where so specified.
- Do not use any fuse that does not meet the specified rating.
- Make complete connections for the IC board and other connectors. Insufficient insertion is very dangerous.

Also, for the IC board circuit inspections, only the logic tone is allowed. The use of a tester is not permitted, so be careful in this regard. After confirming that there are no irregularities, turn the power ON.



## 2. PREVENTION OF COUNTERFEITING AND CONVERSION

### LABELLING

To prevent counterfeits and conversions, the following labels are put on all the SEGA products. When handling such goods, be sure to confirm the labels. They are used to prevent illegal acts such as the unauthorized copying of the products and the printed circuit boards thereof or carrying on business by manufacturing similar merchandise or by converting, selling or using such products or printed circuit boards.

#### ORIGINAL SEAL

The following seal is put on the machines manufactured by SEGA.



#### LICENSE SEAL

The following seal is put on the kits, such as the printed circuit boards, of SEGA products.



### COPYRIGHT NOTICE

This SEGA product has the copyright notice as follows:

© SEGA 1988

This signifies that this work was disclosed in 1988 and is the property of SEGA ENTERPRISES, LTD.



### 3. PRECAUTIONS CONCERNING THE PLACE OF INSTALLATION

The GALAXY FORCE is an indoor game machine. Absolutely do not install it outside. Even indoors, avoid installing in places mentioned below so as to ensure proper usage:

- Places subject to rain or water leakage, or condensation due to humidity.
- In the proximity of an indoor swimming pool and/or shower.
- Places subject to direct sunlight.
- Places subject to heat sources from heating units, etc., or hot air.
- Vicinity of highly inflammable/volatile chemicals or hazardous matter.
- Sloped surfaces.
- Vicinity of anti-disaster facilities such as fire exits and fire extinguishers.
- Places subject to any type of violent impact.
- Dusty places.

#### PRECAUTIONS FOR INSTALLATION

1. In order to ensure the customers' safety, provide the guard fence in the periphery of the machine and make sure that the beam sensors, power cords and switches are accurately adjusted and maintained.
2. Make sure that the power supply outlet is used exclusively for the AFTER BURNER. (The outlet's simultaneous use for other machine(s) may cause the breaker to break when the power consumption exceeds the maximum).
3. An extension cord used shall be of a 15A rated current or higher.

The machine's consumption current

Rated current : 2.8A (100V AC)  
(standby)

Maximum : 12A (100V AC)

During game play: 2.8 ~ 12A (100V AC)



## 4. INSTALLATION PRECAUTIONS AND MOVING THE MACHINE

### INSTALLATION PRECAUTIONS

The machine is equipped with 4 castors and 4 leg adjusters. When the installation position is determined, make sure that there is approximately a 5 mm gap between the floor level and the castors. An insufficient gap may cause the machine to move during game play and result in a dangerous situation.

### MOVING THE MACHINE

The machine weighs approximately 882 lbs. (400 kg.), therefore, when moving it on the floor, lift the leg adjusters.

Before turning the power ON,  
follow the procedure below:

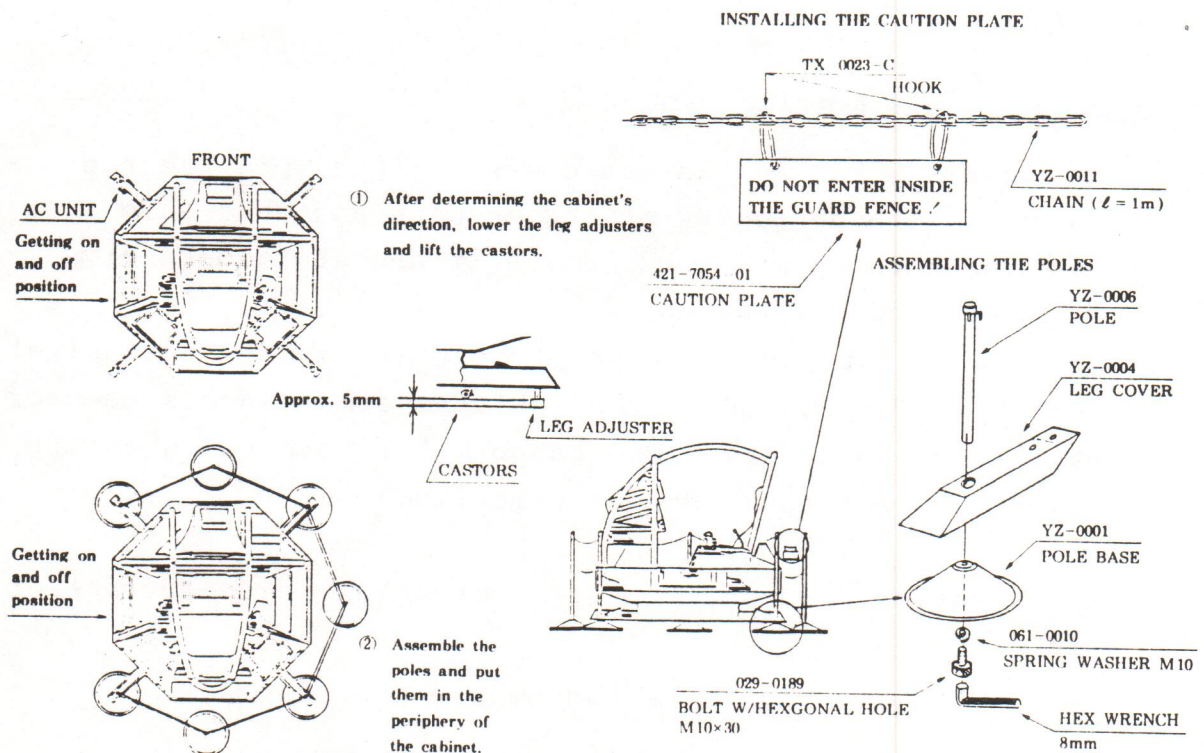



## 5. DISASSEMBLING

When disassembling the machine for the purposes of carrying it through narrow places for installation, etc., follow the procedure below.

### PROCEDURE:

1. Remove ① UNDER PANELS as shown at the 5 places marked with an arrow.
2. Take off ② 2 MAIN BARS.
3. Take off ③ SHEET.
4. Remove ④ MONITOR STAND, ⑤ ROLL HOOP, and ⑥ RAIL. At this time, put the main board connectors and the monitor cords inside the TURNTABLE.

After disassembling the machine in the above procedure, if it can not pass through narrow places when it is positioned sideways, then disassemble the following units:

5. Remove ⑦ FOOT COVER RIGHT and CONNECTORS.
6. Remove ⑧ CONTROL COVER, ⑨ CONTROL UNIT and disconnect CONNECTORS.
7. Remove ⑩ THROTTLE COVER, ⑪ THROTTLE UNIT, and disconnect CONNECTORS.
8. Remove ⑫ BILLBOARD and disconnect CONNECTORS.
9. Remove ⑬ FOOT COVER LEFT and ⑭ FOOT COVER FRONT.

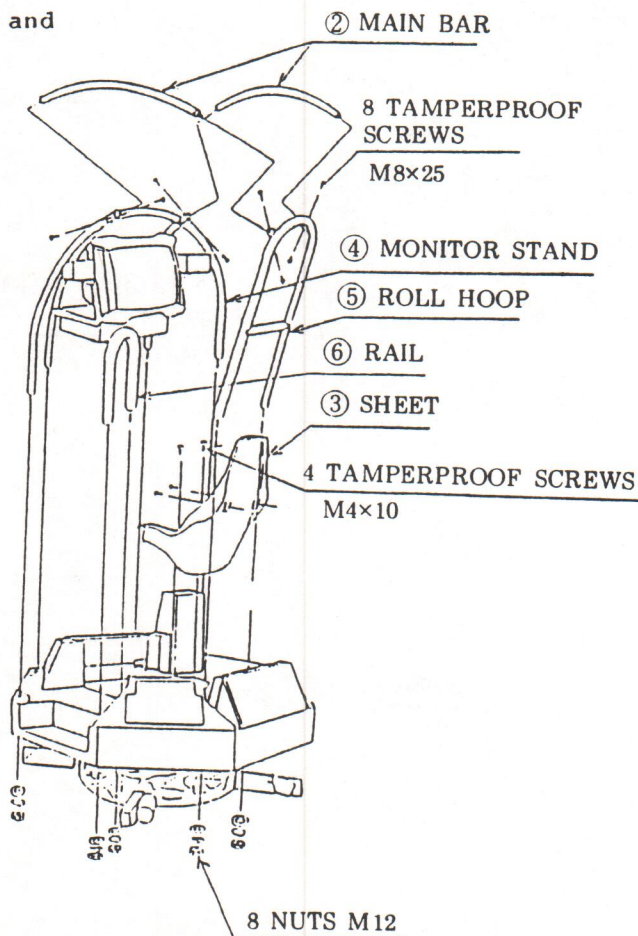
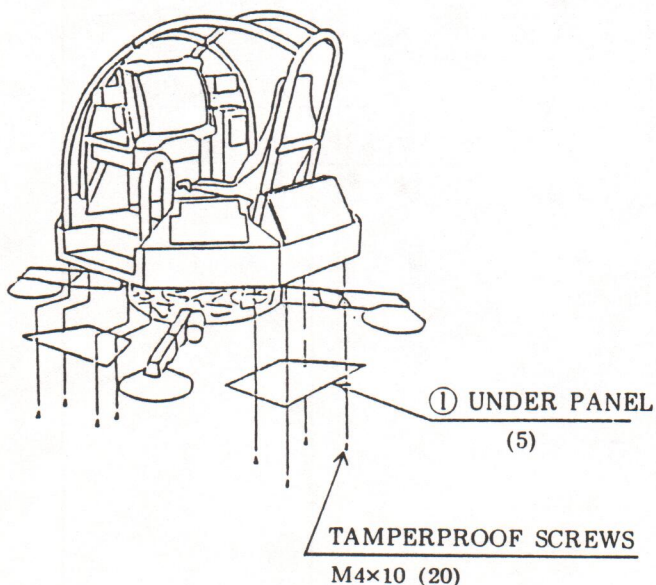
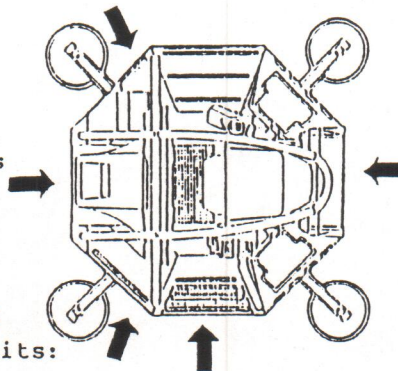



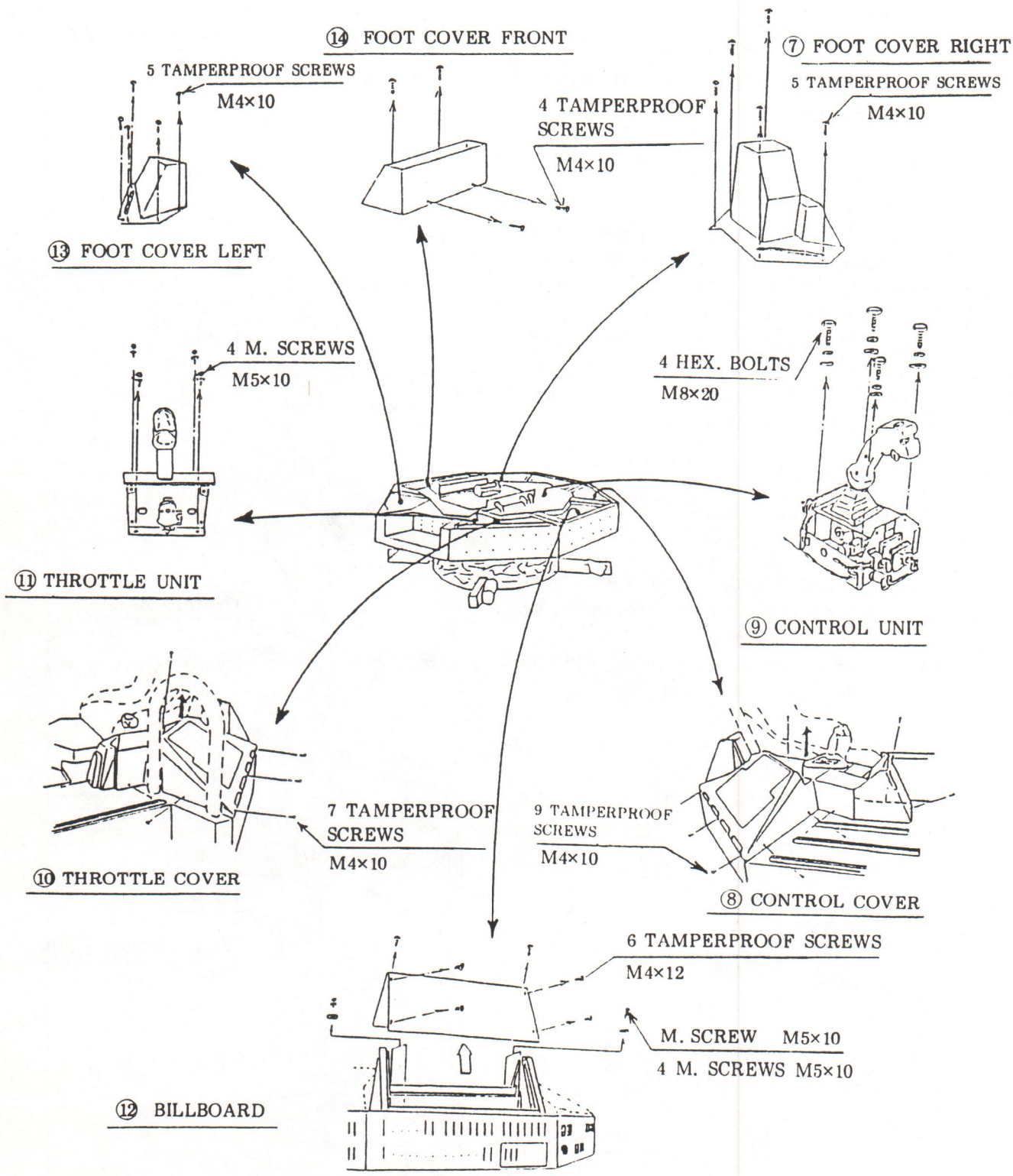



## 6. NAME OF PARTS

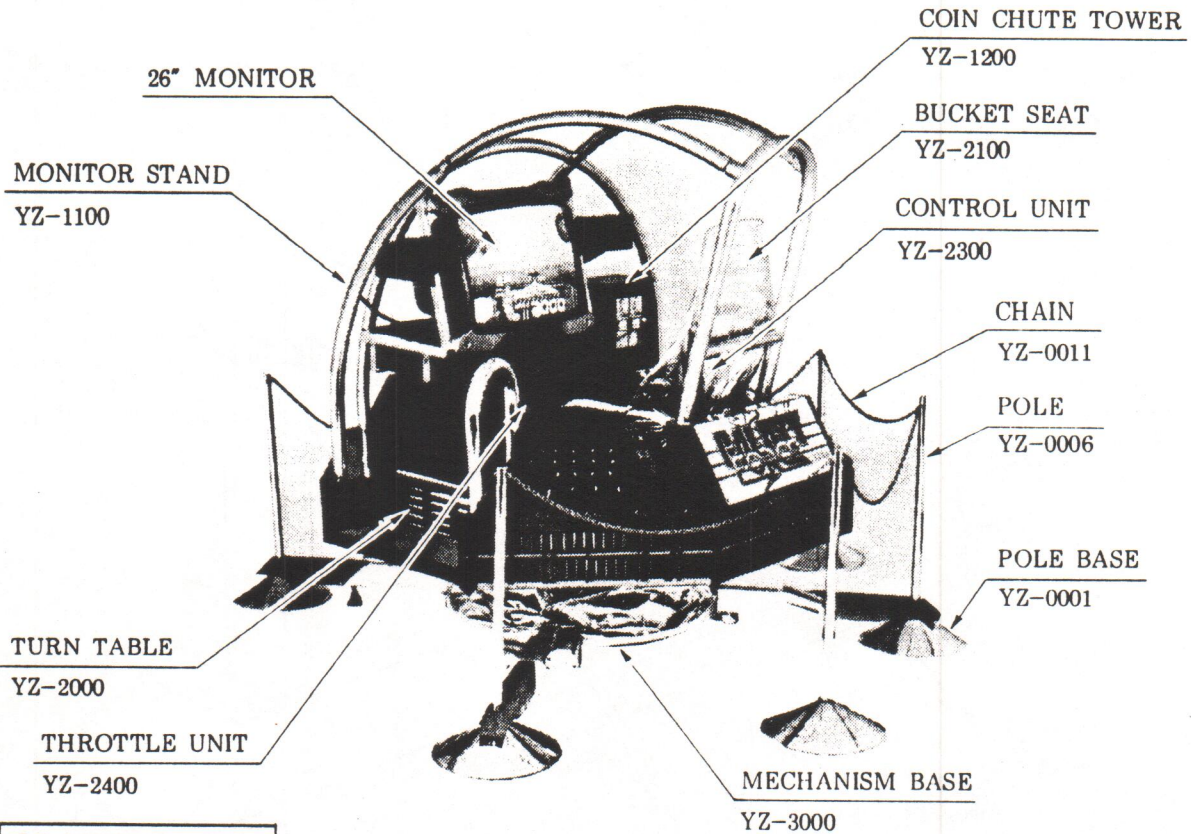

### SPARE PARTS

- 220-5130 VOL. CONTROL B 5 K.Ω
- 390-5223 FL. 9W BLUE
- 090-0025 GREASE SPRAY TYPE
- SGB-3888-82 WIRE HARN, SOUND
- 540-0006-01 WRENCH FOR TAMPER SCREW M4
- 540-0007-01 WRENCH FOR TAMPER SCREW M5
- 540-0009-01 WRENCH FOR TAMPER SCREW M8
- 540-0024 L-WRENCH FOR HEX SOC. 8mm
- 601-5910 BRUSH FOR MOTOR
- 601-6150 BRUSH FOR MOTOR

### TOOLS

(TAMPERPROOF WRENCH)

- M4 540-0006-01
- M5 540-0007-01
- M8 540-0009-01

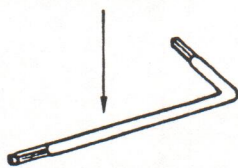

(TAMPERPROOF DRIVER)

- M4 540-0018
- M5 540-0017

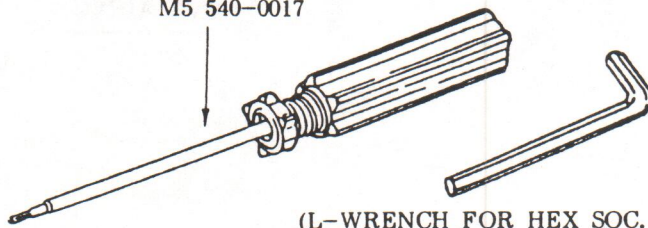

(L-WRENCH FOR HEX SOC. 8mm)

540-0024



## 7. AC UNIT

When the power switch is turned ON, the start button flashes and the unit goes into a standby condition.

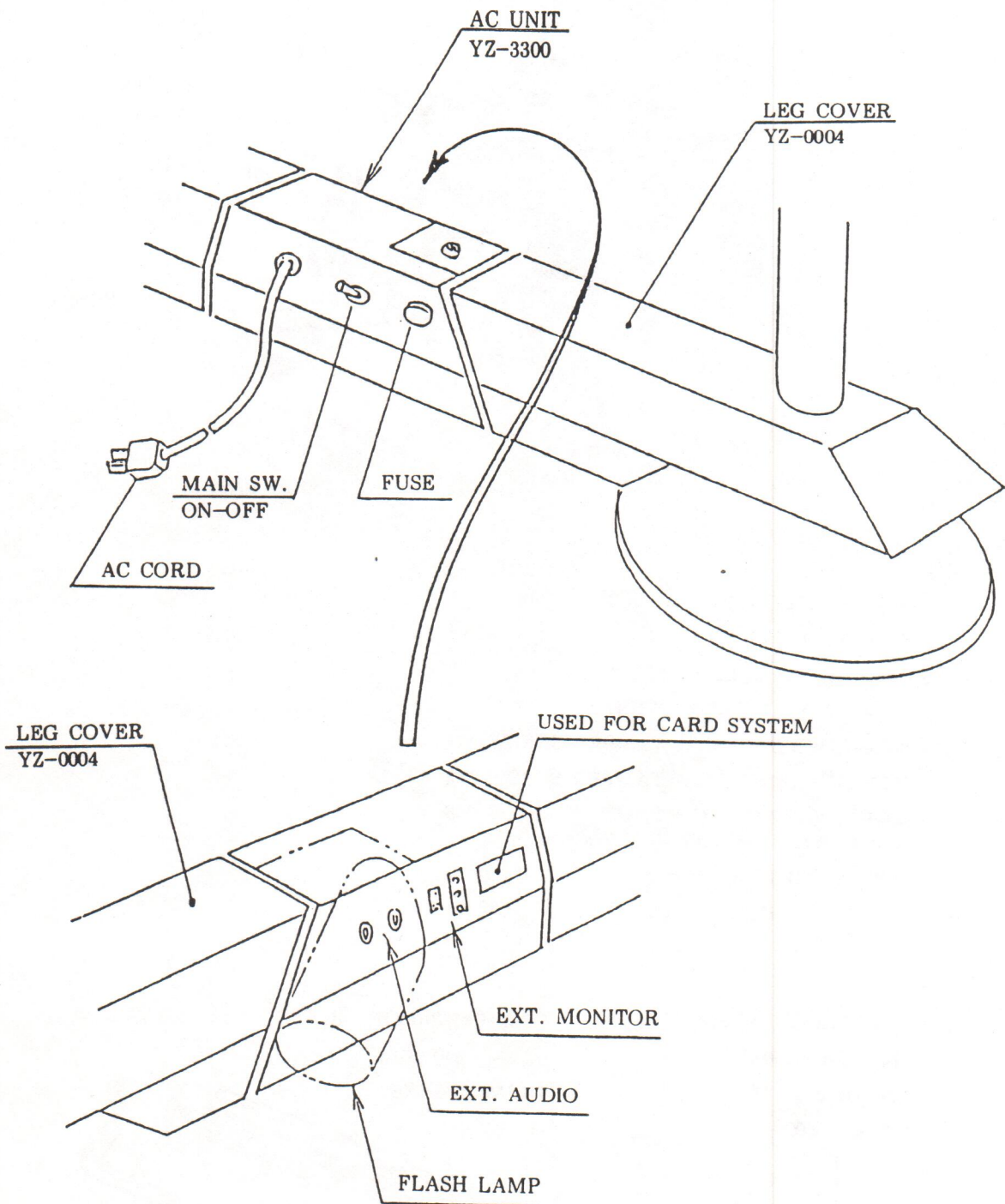

FUSE  
100V ~ 120V AREA ..... 15A  
200V ~ 240V AREA ..... 10A



## 8. CAUTIONS TO BE TAKEN WHEN TURNING THE POWER ON

Refrain from turning the power ON simultaneously for more than one machine. Drastic decrease in the power supply voltage may cause the machine not to start up properly. When turning the power ON, make sure that there is no obstacles in the machine's mobile range.

### WARNING

After turning the power ON, when the screen display as shown appears, push the START BUTTON.

#### PUSH START BUTTON TO CENTERING

The cabinet performs the function of centering and will be in a state to accept coins.

However, immediately after transporting or when adjusting the machine, or in such similar cases, enter the test mode by using the test switch without pushing the START BUTTON after turning the power ON.

#### ACCEPTING THE COINS

The COIN CHUTE TOWER is installed on the cabinet's mobile part (YZ-2000).

Therefore, in order to prevent the COIN CHUTE from malfunctioning due to the cabinet's movements, the machine is equipped with a COIN BLOCKER.

The COIN BLOCKER accepts coins only when the cabinet is level against the floor and rejects coins when it is inclined at an angle which exceeds a certain degree.

Also note that when the cabinet's angle detecting V.R. value is not correct, coins may not accurately be inserted even if the COIN BLOCKER is in a state to be able to accept them.



## 9. ADJUSTING THE THROTTLE

### REMOVING THE COVER

First, remove THROTTLE PLATE (YZ-2703) and PLATE BASE (YZ-2704) which are attached to the COVER by taking off the 4 TAMPERPROOF SCREWS (M4 x 10), and remove COVER PLATE (YZ-2702) by taking off the 2 TAMPERPROOF SCREWS (M4 x 16).

The COVER (YZ-2700) can be removed by taking off the 7 TAMPERPROOF SCREWS (M4 x 10) and the 7 (M5) FLAT WASHERS; and by disconnecting the CONNECTOR.

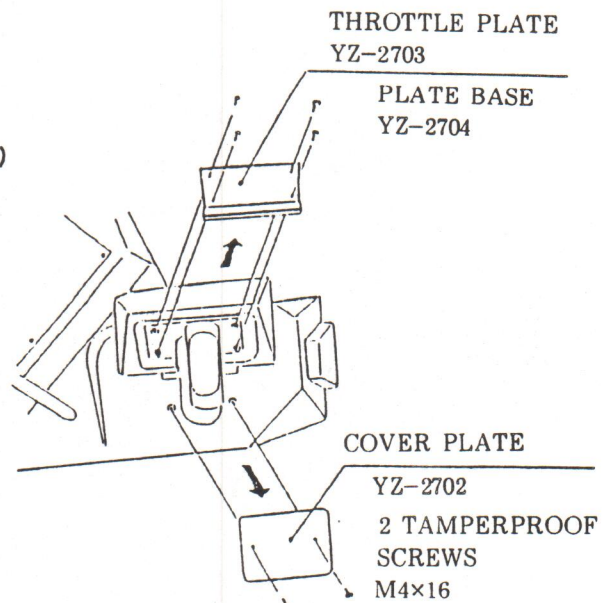

### V.R. ADJUSTMENT

Adjust the V.R. numerical values on the INPUT TEST screen in the TEST MODE (see SELF-TEST) by following the below procedure:

With the throttle lever centrally positioned, loosen SCREW A, turn GEAR A and make sure that the on-screen throttle value is in the vicinity of 80H.

When fastening the screw, adjust the gear's backlash. Also, loosen GEAR B, turn it and make fine adjustments ( $80H+1$ ).

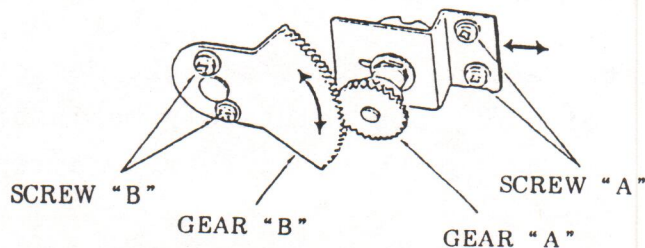
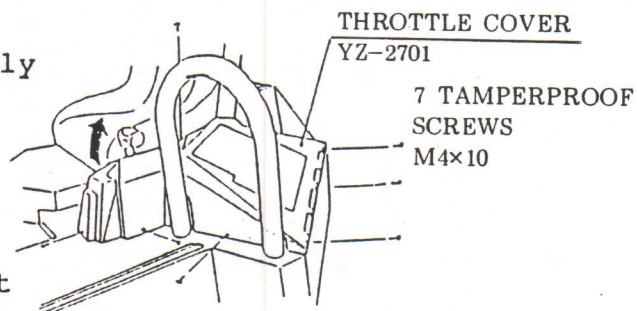



## 10. ADJUSTING THE HANDLE UNIT

### REMOVING THE COVER

Take off the 9 TAMPERPROOF SCREWS (M4 x 10), and the 9 FLAT WASHERS M5; disconnect the 3 CONNECTORS and then remove the COVER.

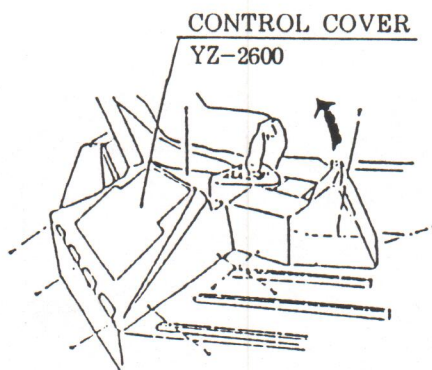

9 TAMPERPROOF SCREWS  
(M4x10)  
9 FLAT WASHERS  
(M5)

### V.R. ADJUSTMENT

Adjust the V.R. numerical values on the INPUT TEST SCREEN in the TEST MODE (see SELF-TEST). When adjusting the V.R. in the horizontal direction, with the handle grip centrally positioned, loosen SCREW A, turn GEAR A and make sure that the on-screen LEVER RIGHT/LEFT value is in the vicinity of 80H. When fastening the SCREW, adjust the gear backlash. Also, loosen SCREW B, turn the ADJUSTING PLATE and make fine adjustments ( $80H \pm 1$ ).

When adjusting the V.R. in the forward/backward direction, similarly adjust each gear in a manner so that the on-screen LEVER UP/DOWN value becomes  $80H \pm 1$ .

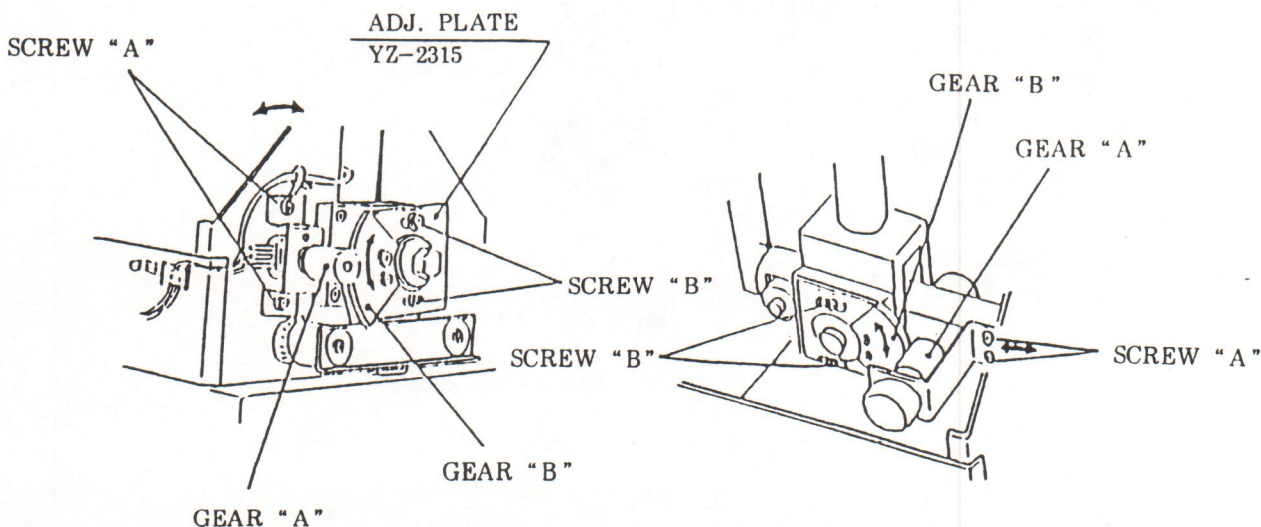



## 11. REMOVING THE MECHANISM UNIT

1. Take off LEG COVERS, red (YZ-0002,-0003) attached to the BASE and a total of 4 WIRE COVERS, silver (YZ-3010,-3011,-3027).

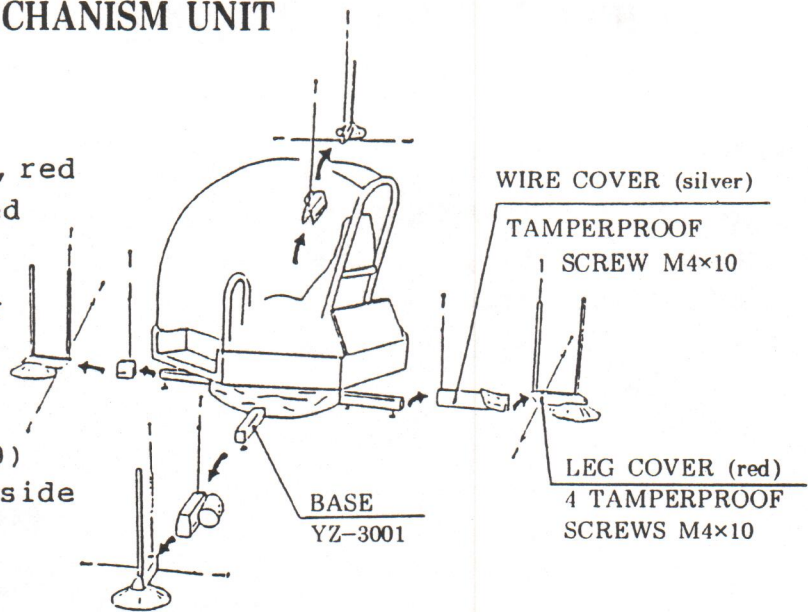

2. Lift BRACKET (YZ-3019) which is on the underside of the BELLOWS and temporarily secure it to the UPPER BRACKET (YZ-3018) by using tape, etc.
3. The DISK COVER can be removed by taking off 2 WING BOLTS M5 x 10.
4. Loosen the M10 nuts which secure the motor bracket and incline the bracket inside so that the BELT (350-5137) can be removed.

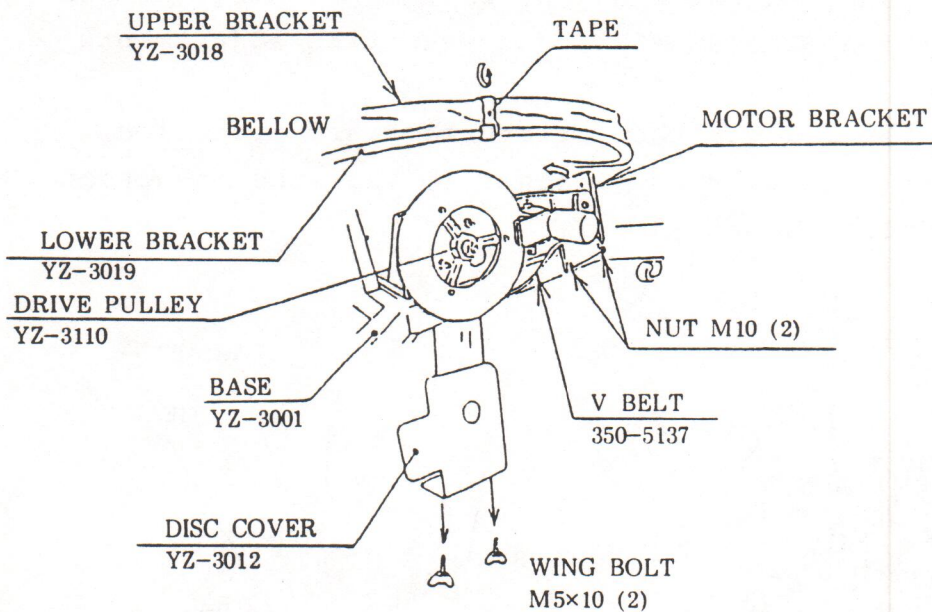



5. Disassemble the mechanism unit and SWING ARM (YZ-3007). At this time, the machine will freely move in the inclined direction with the swing arm disconnected, therefore, perform the necessary work by providing in advance a supporting chair, etc. in the machine's inclined direction for the purpose of facilitating the work.

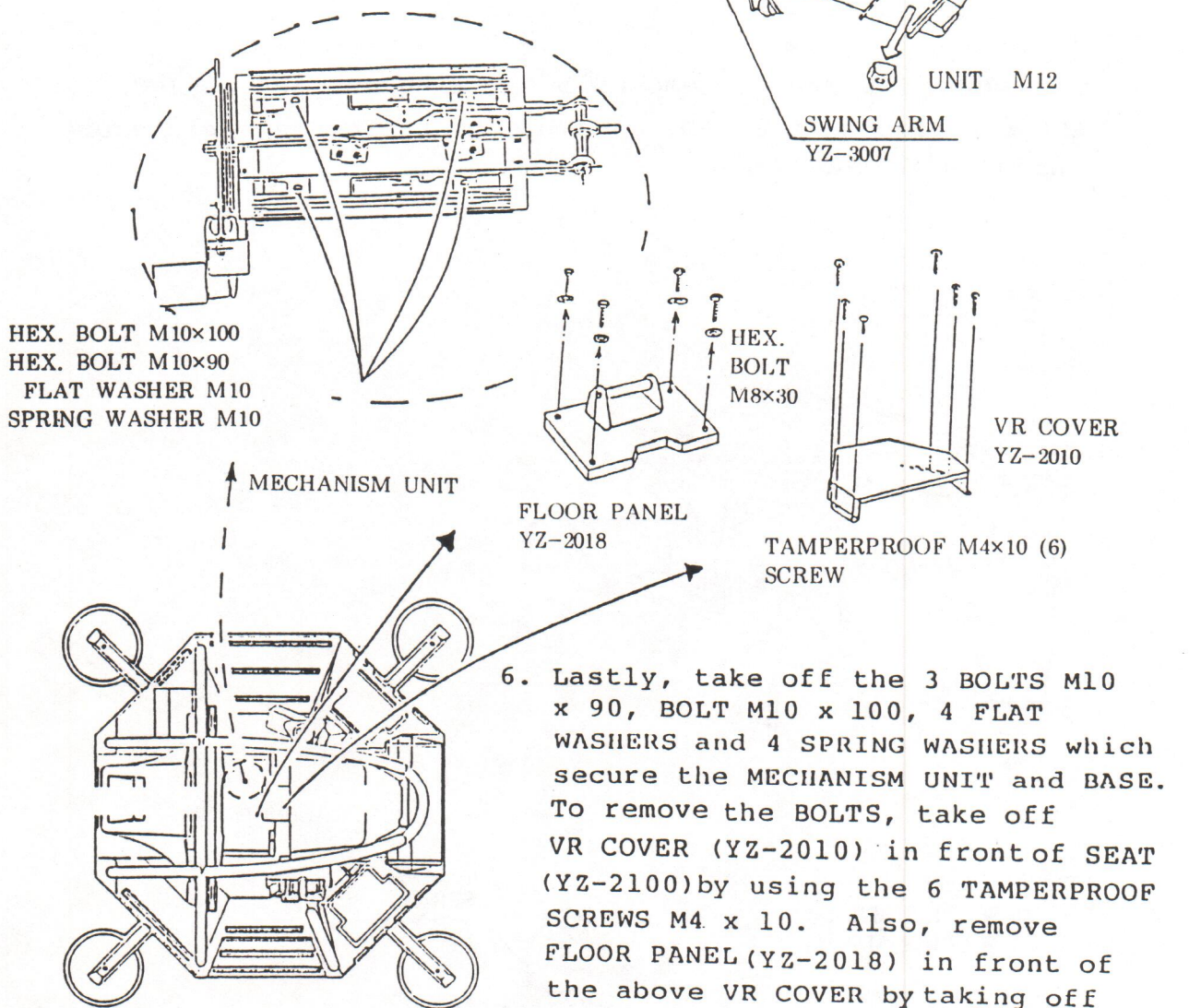

6. Lastly, take off the 3 BOLTS M10 x 90, BOLT M10 x 100, 4 FLAT WASHERS and 4 SPRING WASHERS which secure the MECHANISM UNIT and BASE. To remove the BOLTS, take off VR COVER (YZ-2010) in front of SEAT (YZ-2100) by using the 6 TAMPERPROOF SCREWS M4 x 10. Also, remove FLOOR PANEL (YZ-2018) in front of the above VR COVER by taking off the 4 BOLTS M8 x 30 and the 4 FLAT WASHERS M8. Insert the ratchet wrench with an extension bar attached to it, from the gap between the BASE and TURNTABLE, and remove the mechanism unit.

The mechanism unit is removable in the above procedure.

## 12. REPLACING THE BRAKE PAD

First, remove the CONNECTOR. Then take off BRAKE CALIPER UNIT (610-0219), HEXAGON BOLT M12 x 90, 2 FLAT WASHERS M12, SPRING WASHER and HEXAGON NUT M12 which are used to secure CALIPER BRACKET (YZ-3112). To remove the BRAKE CALIPER UNIT, press one side of it and pull it out as if using a clothespin.

The BRAKE PAD can be removed by pulling out the SPRING. After replacing the PAD, assemble by following a procedure opposite to the above.

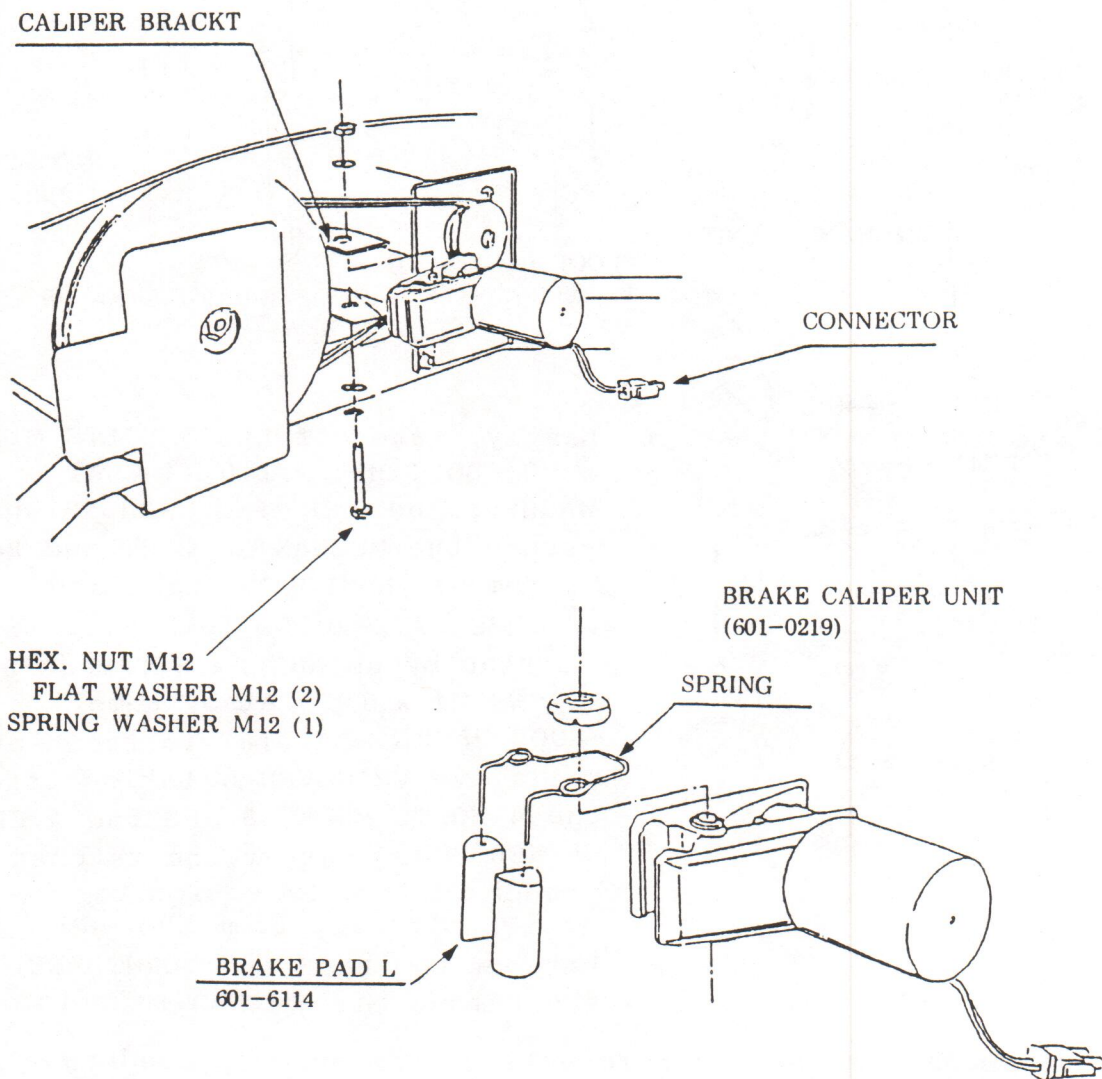



### 13. REMOVING THE MOTOR UNIT

1. Remove DESIGN PLATE (YZ-2502 acryl board) upward by taking off the 6 TAMPERPROOF SCREWS (M4 x 12) which are used to secure it.
2. Disconnect the 2 CONNECTORS which come from the motor.
3. Remove the MAINTENANCE DOOR (YZ-2003) attached to the TURNTABLE by taking off the 2 TAMPERPROOF SCREWS (M4 x 10).
4. Remove UNDER PANEL (YZ-2002) attached to the bottom of the TURNTABLE by taking off the 4 TAMPERPROOF SCREWS (M4 x 10) and 4 WASHERS.

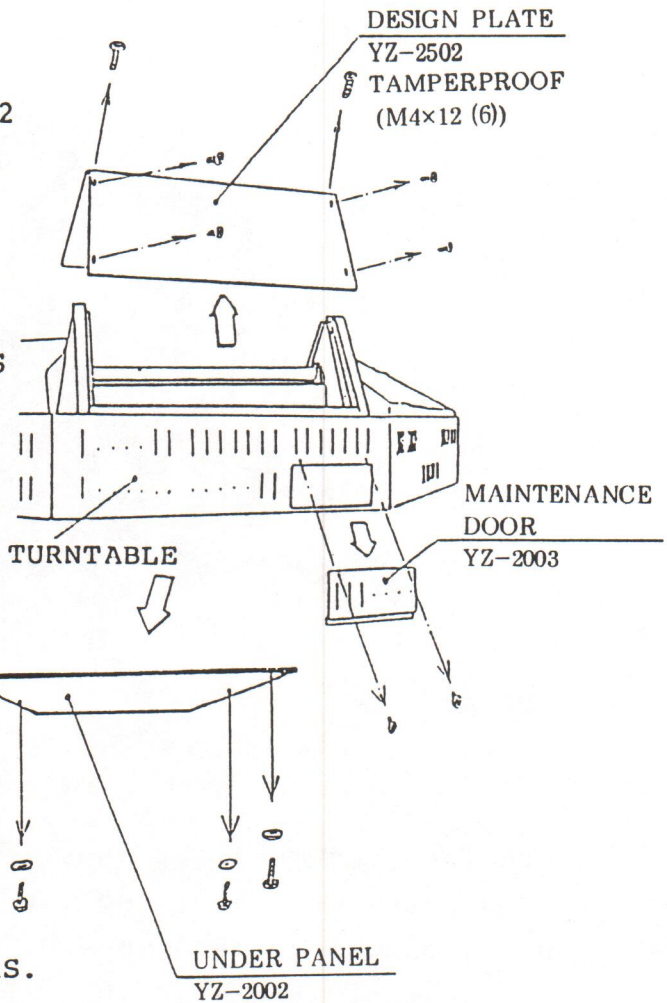

TAMPERPROOF SCREW (4x10 (4))  
FLAT WASHER (M5 (4))

5. Fasten the spring which presses the tire by using the supplied HEXAGON BOLT (M10 x 90). Make sure that the tire is approximately 7-8 mm away from the frame.
6. Pull out the SHOULDER SCREW by taking off the nuts.
7. Remove the MOTOR UNIT from the underside of the TURNTABLE.

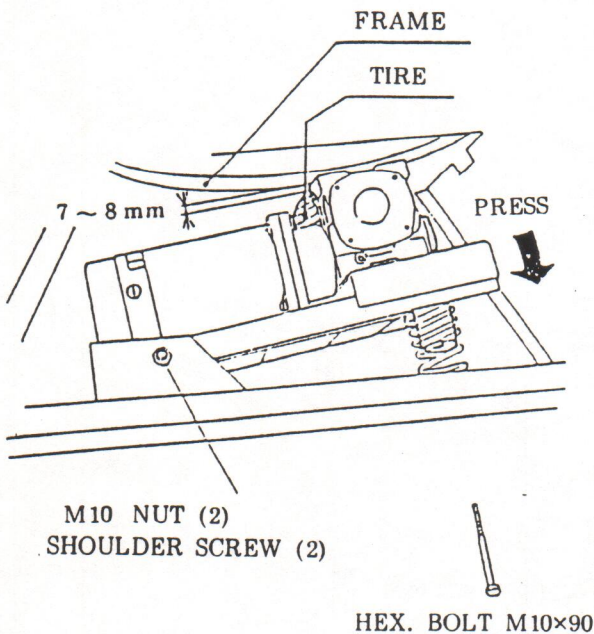

# 14. REPLACING THE MOTOR BRUSHES

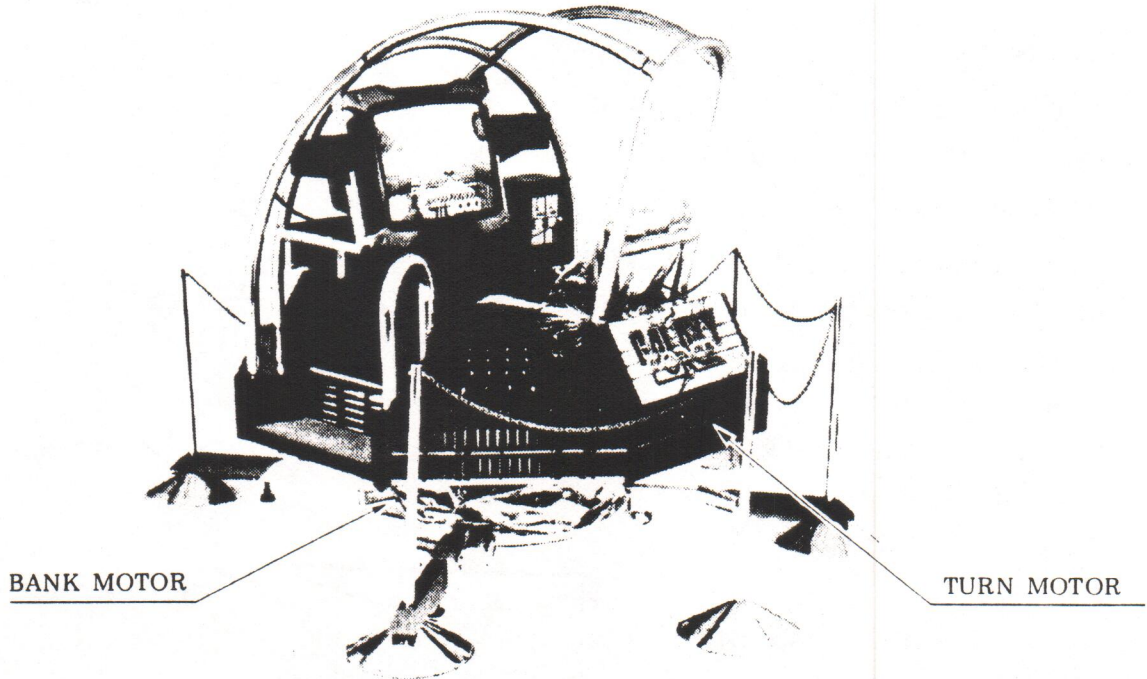

To replace the motor brushes, release the cap with a screwdriver, etc. and take out the brushes. Replacement once every 6 months is recommended. Make sure that both brushes are simultaneously replaced.

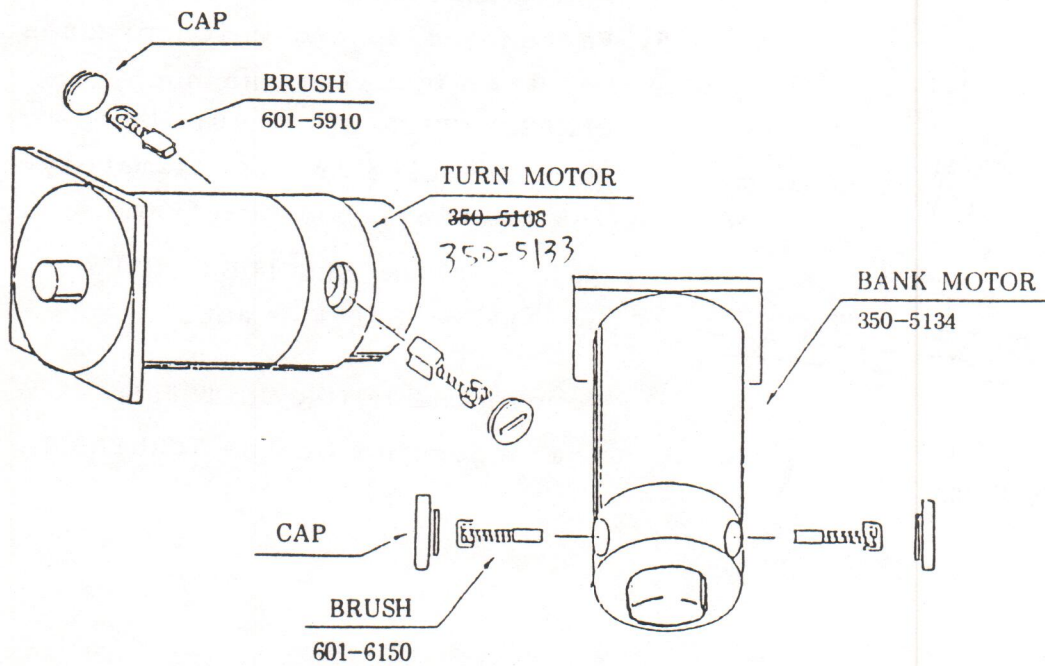



## 15. BANKING ADJUSTMENT

Perform this adjustment as per the motor test in the SELF-TEST (see MOTOR TEST).

1. Remove V.R. (YZ-2010) positioned in front of SEAT (YZ-2100) by using the 6 TAMPERPROOF SCREWS M4 x 10. Also, remove FLOOR PANEL (YZ-2018) in front of the V.R. COVER by using the 4 BOLTS M8 x 30 and 4 WASHERS M8.
2. Take off the 4 WING BOLTS (M5 x 10) which secure BELLOW (YZ-3017). At this time, in the case where you can not reach the working spot, move the TURNTABLE by using the motor and perform such work from an easy access position. Also, turn CIRCULAR BRACKET (YZ-3018) clockwise and drop it.

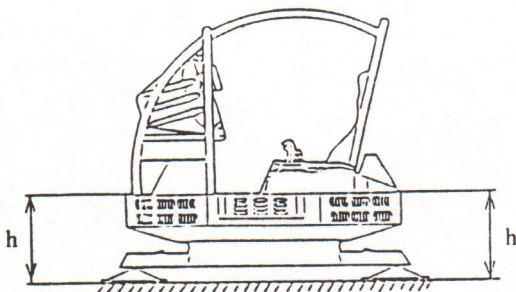
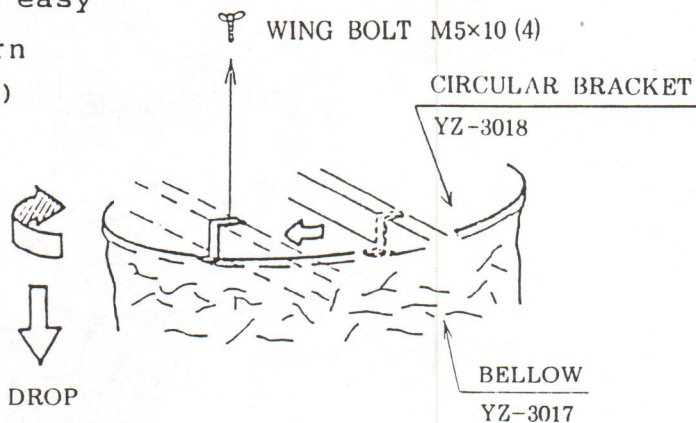
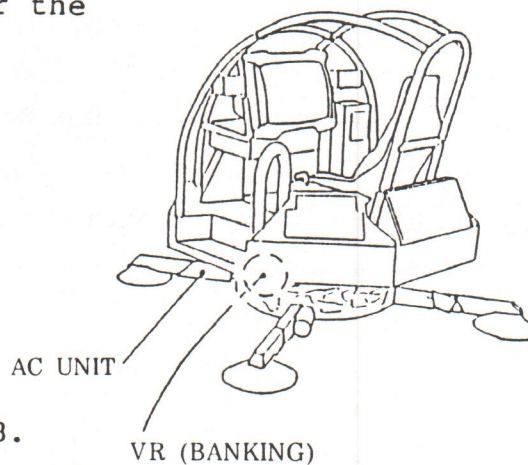

3. Make sure that the cabinet is in a level position. Move the cabinet by using the motor in a manner to ensure that DISTANCE h to the TURNTABLE surfaces both at the front and the back is the same.

#### 4. V.R. ADJUSTMENT

After confirming that the cabinet is level, make sure that the BANKING value displayed on the MOTOR TEST screen is  $80H+2H$ . First, loosen SCREW "A" and turn GEAR "B" in a manner so that the on-screen BANKING value will be in the vicinity of  $80H$ . When fastening the screws, adjust the gear backlash. Also, loosen SCREW "B", turn the ADJUSTING PLATE and make fine adjustments to  $80H+2$ .

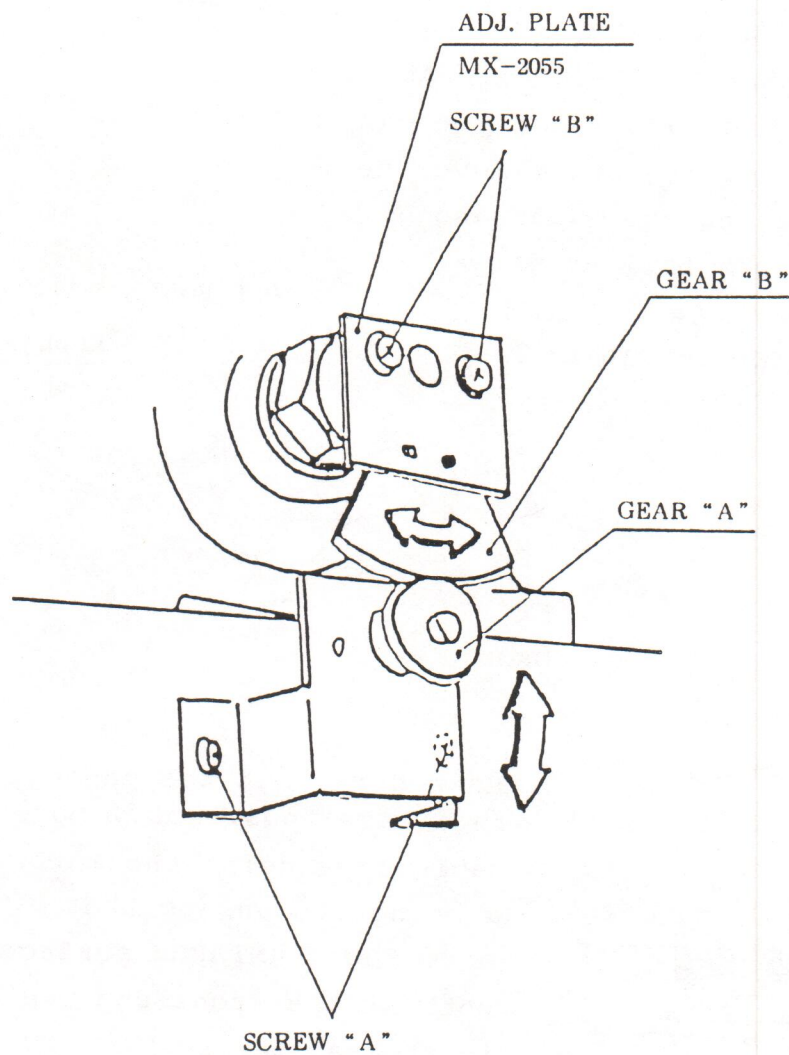



## 16. TURN ADJUSTMENT

Perform the turn adjustment as per the motor test in SELF-TEST (see MOTOR TEST).

1. Remove V.R. COVER (YZ-2010) in front of BUCKET SEAT (YZ-2100) by using the 6 TAMPERPROOF SCREWS M4 x 10. Also, remove GEAR COVER (YZ-2017) inside the V.R. COVER by using the 2 SCREWS M4 x 10 W/SF.

2. Make sure that the TURNTABLE corresponds with the center position. From the functional point of view, said center position is hard to recognize, therefore, note the following as reference:

- A. When the TURNTABLE and BASE (YZ-3000) were reassembled after disassembling; The TURNTABLE's center position is where RUBBER WHEEL  $\varnothing 75$  (601-5861) attached to the vicinity of the TURNTABLE's seat corresponds to the center of STOPPER (YZ-3003).

- B. When inspections and or readjustments are made in cases other than A; The center is where the side of the TURNTABLE, which is next to the TURNTABLE step towards the monitor, is at the right angle with the frame to which the AC UNIT is attached.

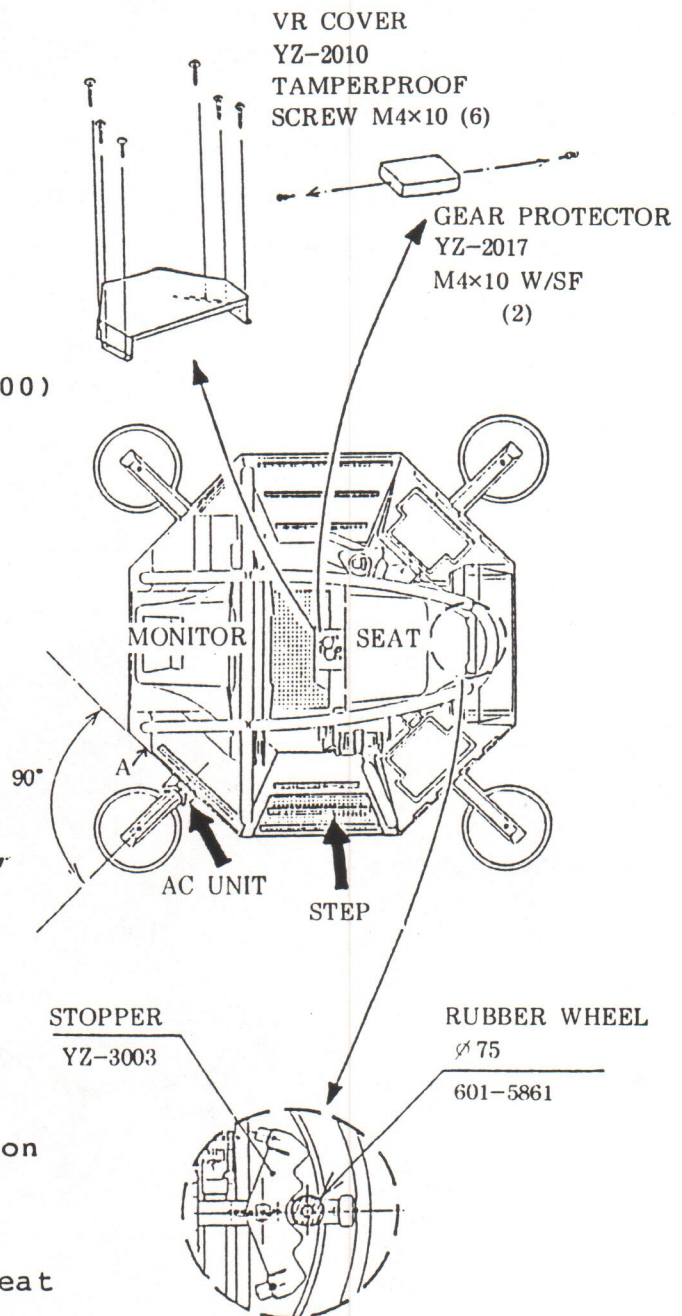

### 3. V.R. ADJUSTMENT

After confirming that the TURNTABLE matches the center position, make sure that the TURNTABLE value displayed on the MOTOR TEST screen is  $80H \pm 1H$ . Loosen SCREW "A" and turn GEAR "A" in a manner so that the value will be in the vicinity of  $80H$ . When fastening the screws, adjust the backlash of each gear. Also, make fine adjustments ( $80H \pm 1$ ) by loosening SCREW "B" and turning GEAR "B."

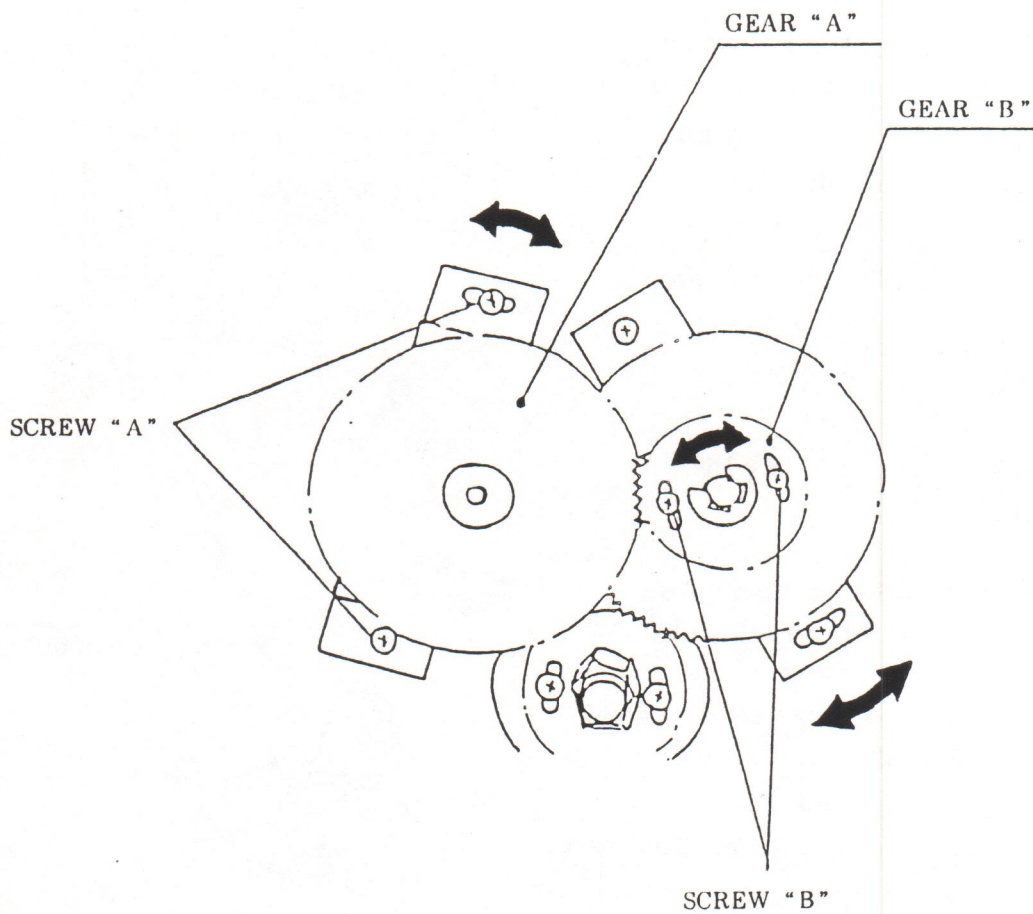



## 17. ADJUSTING THE INFRARED SENSORS

If any obstacles are in between the sensors, the machine stops operating for safety purposes. However, it also stops similarly in the case where the sensor's direction is not correct. Therefore, if the machine does not operate even when there is no obstacles in between the sensors, and the red LED lamp within the light receiving sensor continues to light up, the sensor's direction may not be correct, therefore, make adjustments in the following procedure:

When adjusting the sensor direction, take off the TAMPERPROOF SCREW M4 x 10 and remove SENSOR COVER (YZ-0007).

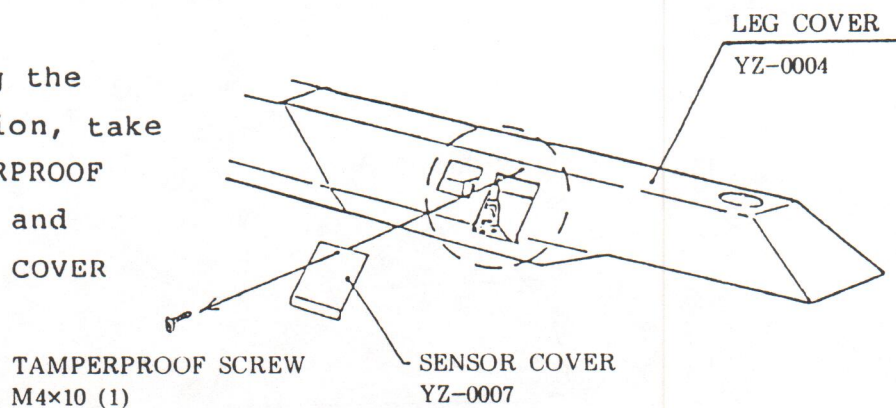

By loosening the 2 SCREWS A, the UP/DOWN adjustment can be made, and by loosening the 2 SCREWS B from the underside of LEG COVER (YZ-0004), the LEFT/RIGHT adjustment can be made. Visually make sure that the sensor's light emitting side and light receiving side faces each other, and make adjustments until the red LED within the light receiving side sensor goes off.

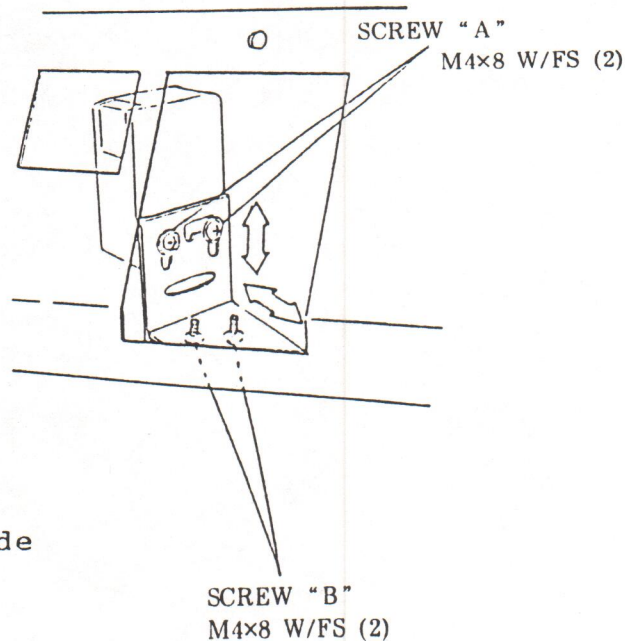

## 18. REPLACING THE BILLBOARD LAMP

1. Take off the 6 (M4 x 12) TAMPERPROOF SCREWS which secure DESIGN PLATE (YZ-2502 acryl board),
2. Remove the design plate by pulling it upward.
3. After replacing the lamp, reinstall the design plate according to the procedure opposite to the one used when removing it.

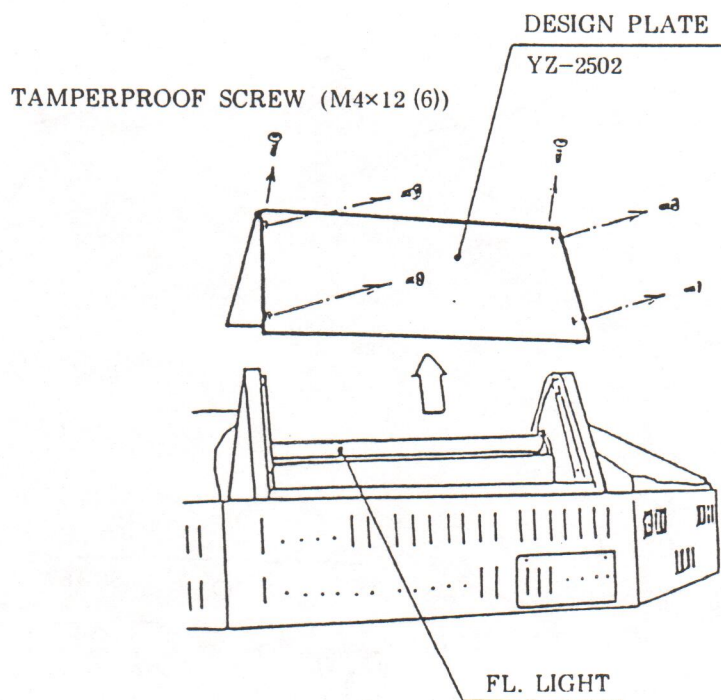



## 19. SELF-TEST

- o Mainly, this test checks whether the game board correctly operates or if there are any defects, makes monitor color adjustments, and performs sound adjustments.

Pushing the TEST SWITCH results in the SELF-TEST screen being displayed. By performing each test, the machine's present state can be evaluated.

### 1. SELECTION OF TEST ITEMS

- (1) Push the TEST SW and the following screen will be displayed:

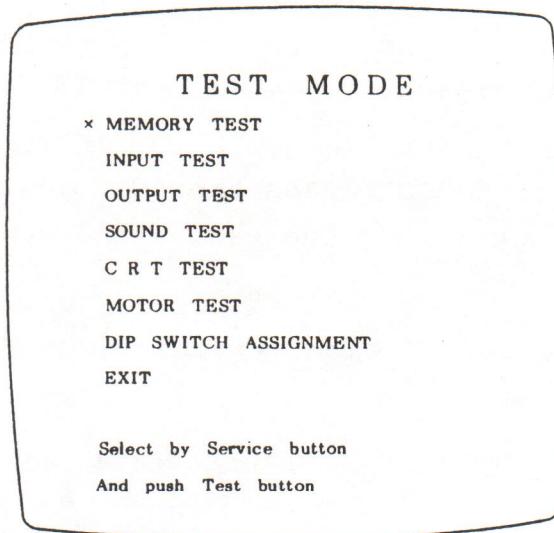

- (2) Each time the SERVICE SW is pushed, the "X" mark moves downwards.
- (3) Bring the "X" mark to the selected item and push the TEST SW again.
- (4) When the tests are finished, bring the "X" mark to EXIT and push the TEST SW.

## 2. FUNCTION OF EACH TEST ITEM

### (1) MEMORY TEST

Checks the program (EP-ROM) and memory (RAM).

MEMORY TEST					
CPU BOARD					
IC 24	Good	IC 28	Good	IC 53	Good
IC 25	Good	IC 29	Good	IC 54	Good
IC 55	Good	IC 80	Good	IC 82	Good
IC 56	Good	IC 81	Good	IC 83	Good
IC 84	Good	IC 86	Good		
IC 85	Good	IC 87	Good		
VIDEO BOARD					
IC 3	Good	IC 27	Good	IC 104	Good
IC 4	Good	IC 28	Good	IC 105	Good

The indication of "GOOD" means the IC No. is OK. Push the TEST button to move on to the next item.

### (2) INPUT TEST

Checks the operation of each switch, lever V.R. and throttle V.R.

① Operate each switch. The "ON" indication means that the corresponding SW is OK.

INPUT TEST		
TEST	LEVER	
SERVICE	RIGHT LEFT	80
START	UP DOWN	80
SHOT	SLOTTLE	80
MISSILE		
COIN 1		
COIN 2		

② This test is OK if the numerical value increases when the handle grip is moved to the right and decreases when it is moved to the left, and becomes 80H when taking your hand off.

③ The test is OK if the numerical value increases when the handle grip is moved forward and decreases when it is moved backward, and becomes 80H when taking your hand off.

④ The test is OK if the numerical value increases when the throttle lever is moved forward and decreases when it is moved backward, and becomes 80H when taking your hand off.



When the TEST is finished, push the TEST button.

(3) OUTPUT TEST

Checks the "ON" and "OFF" of the START LAMP.

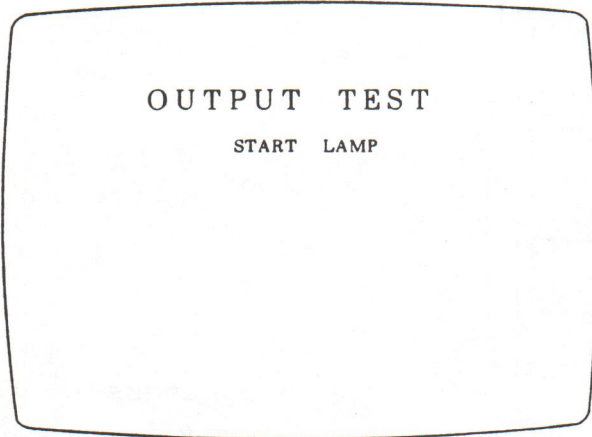

If the lamp flashes, it is OK.

When the test is finished, push the TEST button.

(4) SOUND TEST

Checks the IC board's composite sound.

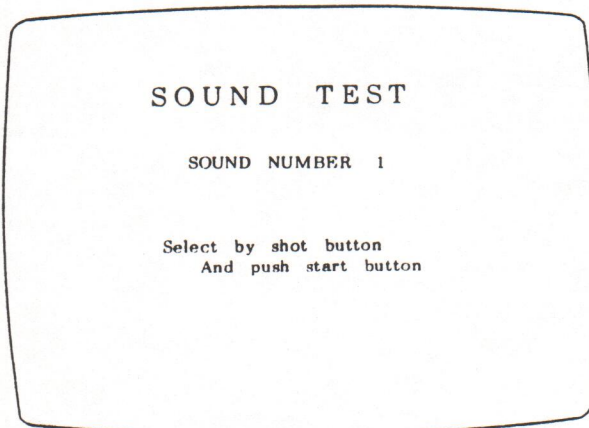

Pushing SHOOT SW 1 increases the number and pushing SHOOT SW 2 decreases the number. Push the START SW when the desired number is shown.

When the TEST is finished, push the TEST button.

(5) CRT TEST

Checks the monitor's colors.

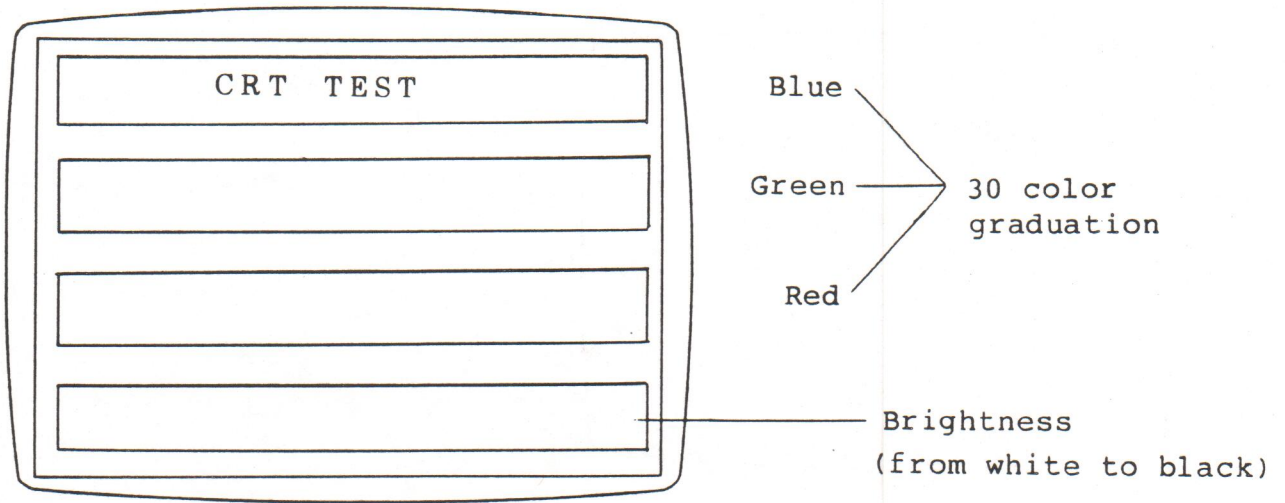

- ① Adjust the screen's position and size by performing the C.R.T. POSITION CHECK.
- ② RGB color check  
Proceeding from the left to the right, the color becomes darker.

When the TEST is finished, push the TEST button.



(6) MOTOR TEST

Checks the limit switch's adjusting angle detecting V.R., and performs the DRIVE BOARD's Self-Test.

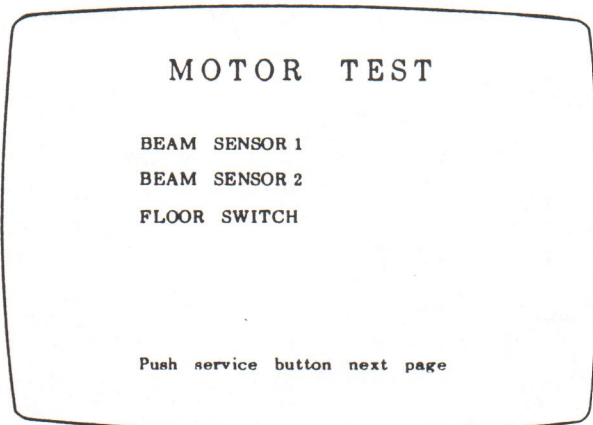

Operate switches. If "ON" is indicated, the corresponding switch is OK.

Push the START button, and the following screen will be displayed:

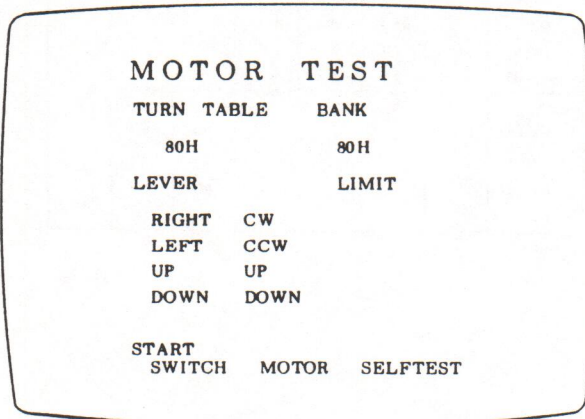

While pulling the handle grip's trigger, operate the handle to move the cabinet, and if "ON" is indicated, the corresponding switch is OK.

When the TEST is finished, push the TEST button.

(7) DIP SW ASSIGNMENT

Displays DIP SW setting status.

DIP SWITCH ASSIGNMENT								
DIP SW. A	1	2	3	4	5	6	7	8
DIP SW. A	off	off	off	off	off	off	off	off
DIP SW. B	off	off	off	off	off	off	off	off
COIN CHUTE 1	1 coin	1 credit						
COIN CHUTE 2	1 coin	1 credit						

Setting of each DIP SW

DIP SW A

Setting of COIN SW

DIP SW B

Game difficulty

COIN/CREDIT OPTIONS SWITCH SETTING DIP SW.A

OPTION	1	2	3	4	5	6	7	8
1 COIN 1 CREDIT	OFF	OFF	OFF	OFF	OFF	OFF	OFF	OFF
1 COIN 2 CREDITS	ON	OFF	OFF	OFF	ON	OFF	OFF	OFF
1 COIN 3 CREDITS	OFF	ON	OFF	OFF	OFF	ON	OFF	OFF
1 COIN 4 CREDITS	ON	ON	OFF	OFF	ON	ON	OFF	OFF
1 COIN 5 CREDITS	OFF	OFF	ON	OFF	OFF	OFF	ON	OFF
1 COIN 6 CREDITS	ON	OFF	ON	OFF	ON	OFF	ON	OFF
2 COINS 1 CREDIT	OFF	ON	ON	OFF	OFF	ON	ON	OFF
3 COINS 1 CREDIT	ON	ON	ON	OFF	ON	ON	ON	OFF
5 COINS 2 CREDITS								
4 COINS 1 CREDIT	OFF	OFF	OFF	ON	OFF	OFF	OFF	ON
2 COINS 3 CREDITS	ON	OFF	OFF	ON	ON	OFF	OFF	ON
2 COINS 1 CREDIT								
4 COINS 2 CREDITS	OFF	ON	OFF	ON	OFF	ON	OFF	ON
5 COINS 3 CREDITS								
6 COINS 4 CREDITS								
2 COINS 1 CREDIT	ON	ON	OFF	ON	ON	ON	OFF	ON
4 COINS 3 CREDITS								
1 COIN 1 CREDIT								
2 COINS 2 CREDITS								
3 COINS 3 CREDITS	OFF	OFF	ON	ON	OFF	OFF	ON	ON
4 COINS 4 CREDITS								
5 COINS 6 CREDITS								
1 COIN 1 CREDITS								
2 COINS 2 CREDITS	ON	OFF	ON	ON	ON	OFF	ON	ON
3 COINS 3 CREDITS								
4 COINS 5 CREDITS								
1 COIN 1 CREDIT	OFF	ON	ON	ON	OFF	ON	ON	ON
2 COINS 3 CREDITS								
FREE PLAY	ON	ON	ON	ON	ON	ON	ON	ON
	COIN SWITCH # 1				COIN SWITCH # 2			

GAME DIFFICULTY SWITCH SETTING

DIP SW.B

SWITCH #	1	2	3	4	5	6	7	8
TIMER	NOT USE						NOT USE	NOT USE
EASIEST		OFF	OFF	OFF				
EASIER		ON	OFF	OFF				
EASY 2		OFF	ON	OFF				
EASY 1		ON	ON	OFF				
NORMAL		OFF	OFF	ON				
HARD		ON	OFF	ON				
HARDER		OFF	ON	ON				
HARDEST		ON	ON	ON				
SHIELD								
5 DAMAGES					OFF	OFF		
6 DAMAGES					ON	OFF		
7 DAMAGES					OFF	ON		
8 DAMAGES					ON	OFF		

When the TEST is finished, push the TEST button.



## 20. REMOVING THE I. C. BOARD (SHIELD BASE)

- ① Open SERVICE DOOR (YZ-1108) of SHIELD PROTECTOR (YZ-1107).
- ② Disconnect the 7 CONNECTORS and 14 NYLACHes to pull out SHIELD BASE (YZ-0008) towards you. (The I.C. BOARD can be removed by pulling out the SHIELD BASE.)

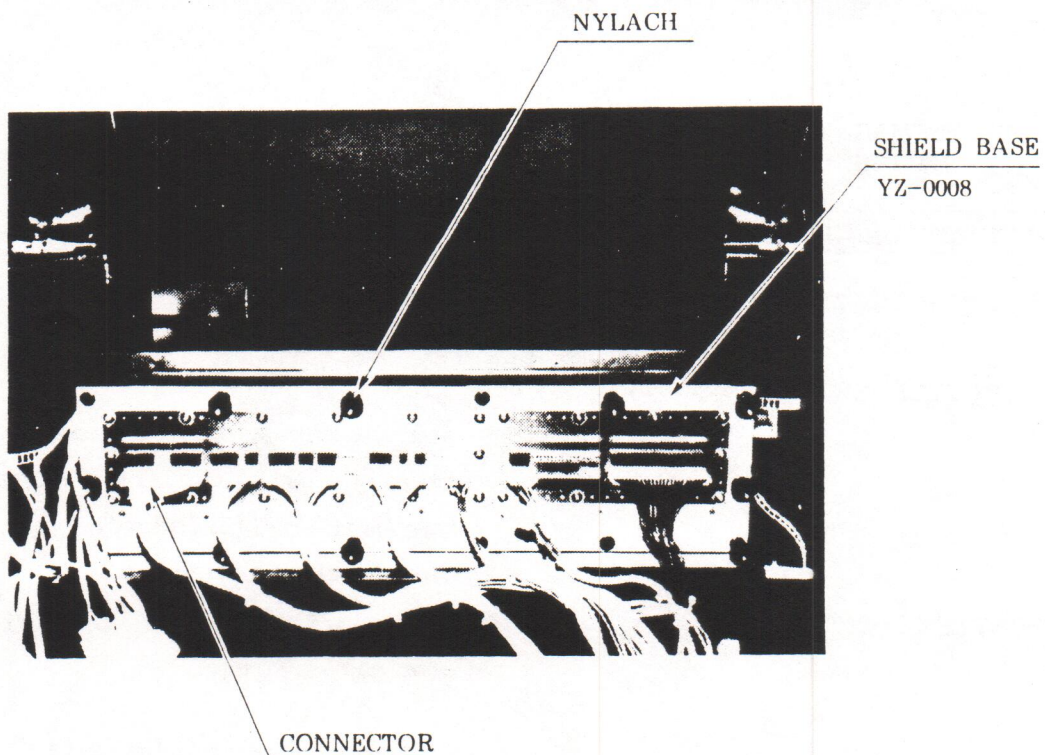
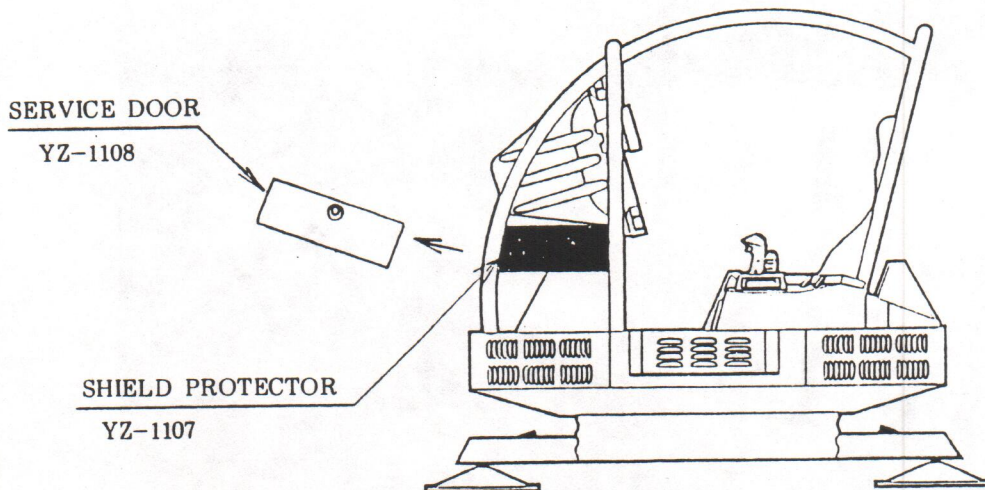

## 21. SERVICE SWITCHES

Open the COIN CHUTE DOOR, and the following SERVICE SWITCHES' layout will appear.

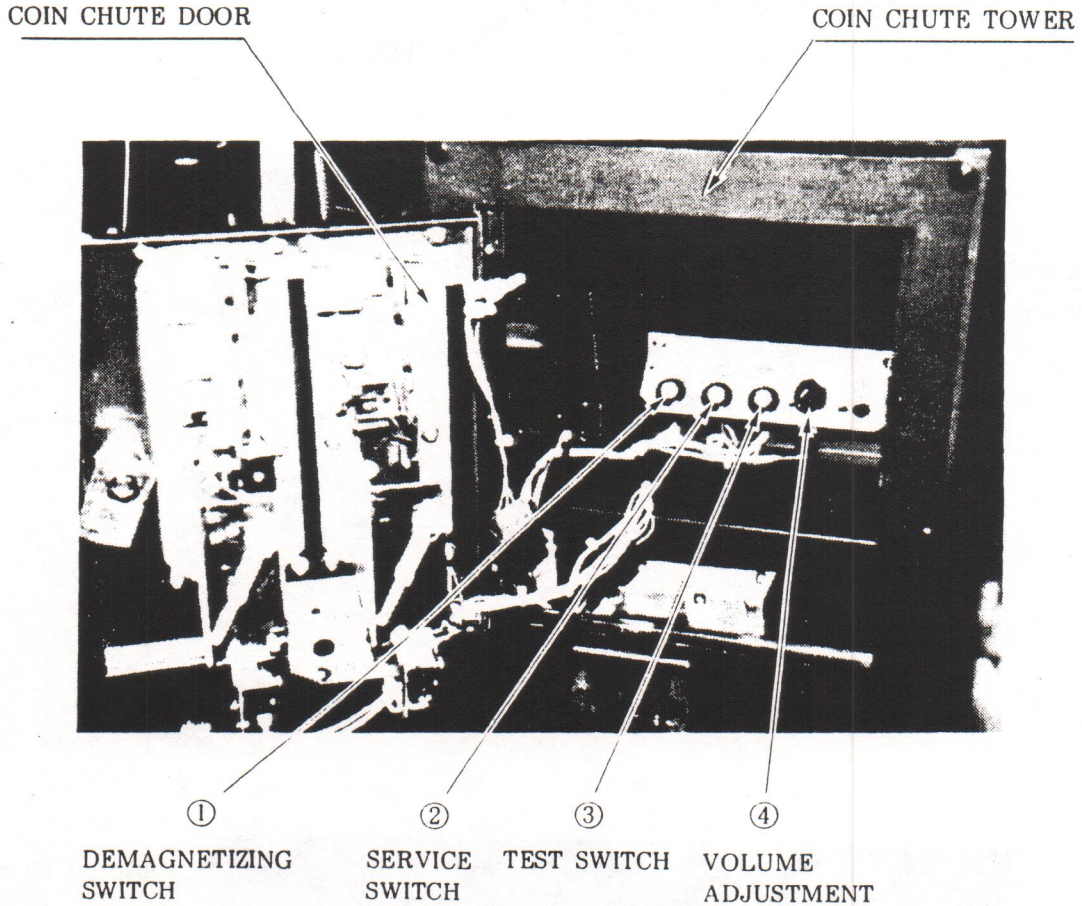

### INSTRUCTIONS

- ① DEMAGNETIZING SWITCH ..... Used for removing the on-screen color unevenness.
- ② SERVICE SWITCH ..... Used for the purpose of servicing and increasing the credits without registering on the meter (this allows you to check the game).
- ③ TEST SWITCH ..... For the operation of this switch, see SELF-TEST.
- ④ VOLUME ADJUSTMENT ..... The volume of the speaker can be adjusted.



## 22. 26 INCH MONITOR

26" MONITOR (NANA0)  
(200-5112-15)

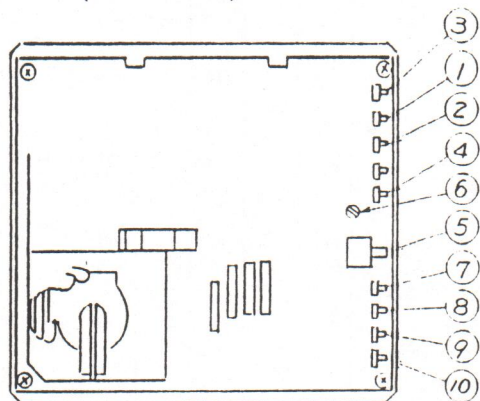

26" MONITOR (SANWA)  
(200-5125-15)

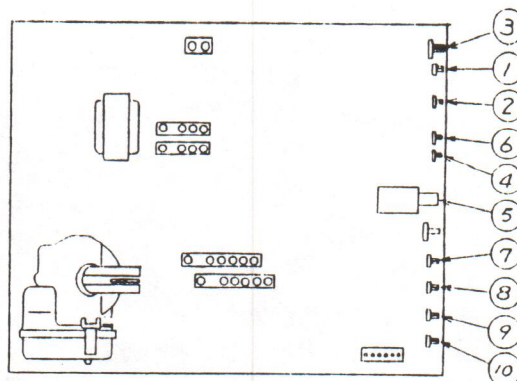

- ① V. HOLD
- ② V. SIZE
- ③ V. POSITION
- ④ H. HOLD
- ⑤ H. SIZE
- ⑥ H. POSITION
- ⑦ BRIGHT
- ⑧ B. GAIN
- ⑨ G. GAIN
- ⑩ R. GAIN

## 23. DIP SWITCH SETTING

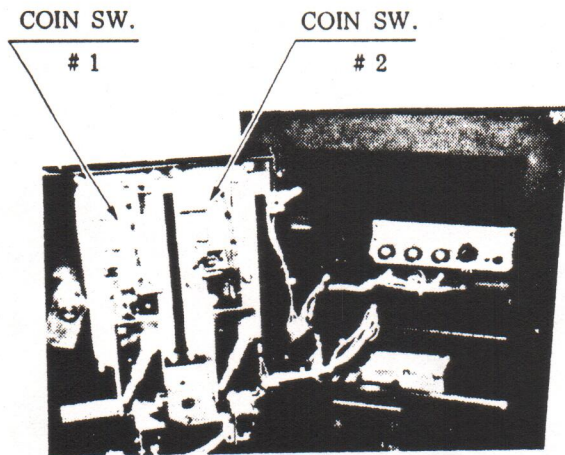

COIN/CREDIT OPTIONS SWITCH SETTING DIP SW.A

OPTION	1	2	3	4	5	6	7	8
1 COIN 1 CREDIT	OFF	OFF	OFF	OFF	OFF	OFF	OFF	OFF
1 COIN 2 CREDITS	ON	OFF	OFF	OFF	ON	OFF	OFF	OFF
1 COIN 3 CREDITS	OFF	ON	OFF	OFF	OFF	ON	OFF	OFF
1 COIN 4 CREDITS	ON	ON	OFF	OFF	ON	ON	OFF	OFF
1 COIN 5 CREDITS	OFF	OFF	ON	OFF	OFF	OFF	ON	OFF
1 COIN 6 CREDITS	ON	OFF	ON	OFF	ON	OFF	ON	OFF
2 COINS 1 CREDIT	OFF	ON	ON	OFF	OFF	ON	ON	OFF
3 COINS 1 CREDIT	ON	ON	ON	OFF	ON	ON	ON	OFF
5 COINS 2 CREDITS								
4 COINS 1 CREDIT	OFF	OFF	OFF	ON	OFF	OFF	OFF	ON
2 COINS 3 CREDITS	ON	OFF	OFF	ON	ON	OFF	OFF	ON
2 COINS 1 CREDIT								
4 COINS 2 CREDITS	OFF	ON	OFF	ON	OFF	ON	OFF	ON
5 COINS 3 CREDITS								
6 COINS 4 CREDITS								
2 COINS 1 CREDIT	ON	ON	OFF	ON	ON	ON	OFF	ON
4 COINS 3 CREDITS								
1 COIN 1 CREDIT								
2 COINS 2 CREDITS								
3 COINS 3 CREDITS	OFF	OFF	ON	ON	OFF	OFF	ON	ON
4 COINS 4 CREDITS								
5 COINS 6 CREDITS								
1 COIN 1 CREDITS								
2 COINS 2 CREDITS	ON	OFF	ON	ON	ON	OFF	ON	ON
3 COINS 3 CREDITS								
4 COINS 5 CREDITS								
1 COIN 1 CREDIT	OFF	ON	ON	ON	OFF	ON	ON	ON
2 COINS 3 CREDITS								
FREE PLAY	ON	ON	ON	ON	ON	ON	ON	ON
	COIN SWITCH # 1				COIN SWITCH # 2			

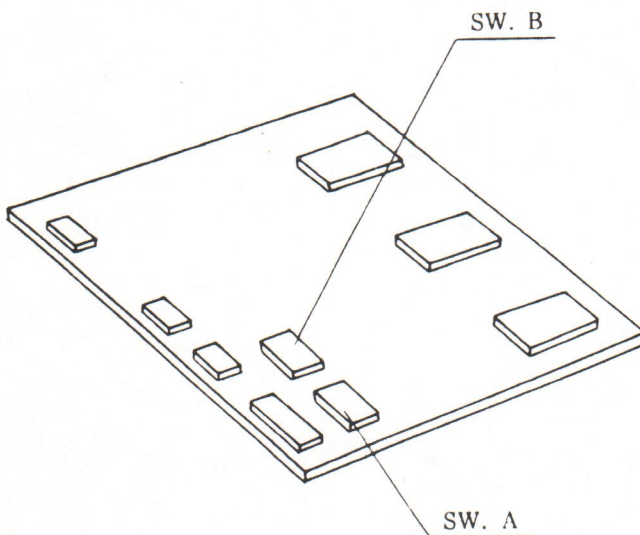

GAME DIFFICULTY SWITCH SETTING DIP SW.B

SWITCH B #	1	2	3	4	5	6	7	8
TIMER	NOT USE						NOT USE	NOT USE
EASIEST		OFF	OFF	OFF				
EASIER		ON	OFF	OFF				
EASY 2		OFF	ON	OFF				
EASY 1		ON	ON	OFF				
NORMAL		OFF	OFF	ON				
HARD		ON	OFF	ON				
HARDER		OFF	ON	ON				
HARDEST		ON	ON	ON				
SHIELD								
5 DAMAGES					OFF	OFF		
6 DAMAGES					ON	OFF		
7 DAMAGES					OFF	ON		
8 DAMAGES					ON	OFF		



## 24. EPROM/MASK ROM LOCATIONS

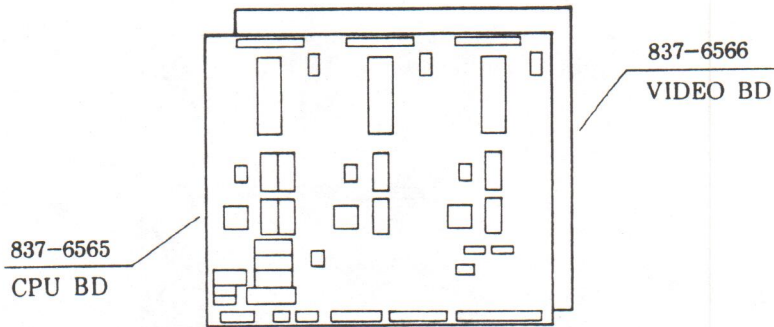

### A. CPU BD GALAXY FORCE 837-6565

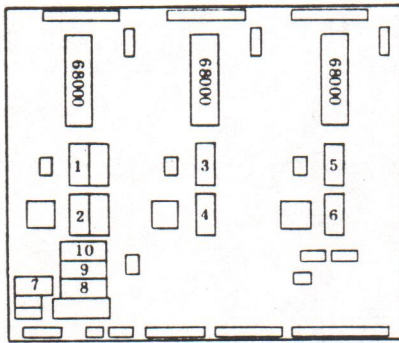

### B. VIDEO BD GALAXY FORCE 837-6566

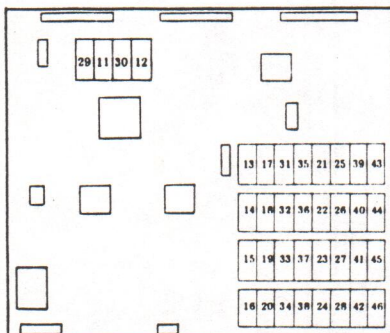

834 - 6614		GAME BD GALAXY FORCE	
837 - 6565		CPU BD	
	IC LOCATION	NUMBER	MAIN WORK
1	IC 24	EPR - 11510	PROGRAM
2	IC 25	EPR - 11511	
3	IC 53	EPR - 11512	
4	IC 54	EPR - 11513	
5	IC 80	EPR - 11514	
6	IC 81	EPR - 11515	
7	IC 102	EPR - 11516A	SOUND PROGRAM
8	IC 107	MPR - 11465	SOUND DATA
9	IC 106	EPR - 11516	
10	IC 105	EPR - 11517	
837 - 6566		VIDEO BD	
11	IC 16	MPR - 11467	OBJECT
12	IC 14	MPR - 11468	
13	IC 67	MPR - 11469	
14	IC 75	MPR - 11470	
15	IC 86	MPR - 11471	
16	IC 114	MPR - 11472	
17	IC 66	MPR - 11473	
18	IC 74	MPR - 11474	
19	IC 85	MPR - 11475	
20	IC 113	MPR - 11476	
21	IC 63	MPR - 11477	
22	IC 71	MPR - 11478	
23	IC 82	MPR - 11479	
24	IC 110	MPR - 11480	
25	IC 62	MPR - 11481	
26	IC 70	MPR - 11482	
27	IC 81	MPR - 11483	
28	IC 109	MPR - 11484	
29	IC 17	EPR - 11518	
30	IC 15	EPR - 11519	
31	IC 65	EPR - 11520	
32	IC 73	EPR - 11521	
33	IC 84	EPR - 11522	
34	IC 112	EPR - 11523	
35	IC 64	EPR - 11524	
36	IC 72	EPR - 11525	
37	IC 83	EPR - 11526	
38	IC 111	EPR - 11527	
39	IC 61	EPR - 11528	
40	IC 69	EPR - 11529	
41	IC 80	EPR - 11530	
42	IC 108	EPR - 11531	
43	IC 60	EPR - 11532	
44	IC 68	EPR - 11533	
45	IC 79	EPR - 11534	
46	IC 107	EPR - 11535	

25. PARTS LIST

① TOP ASSY GALAXY FORCE SUPER DX (YZ-0000) (D-1/3)

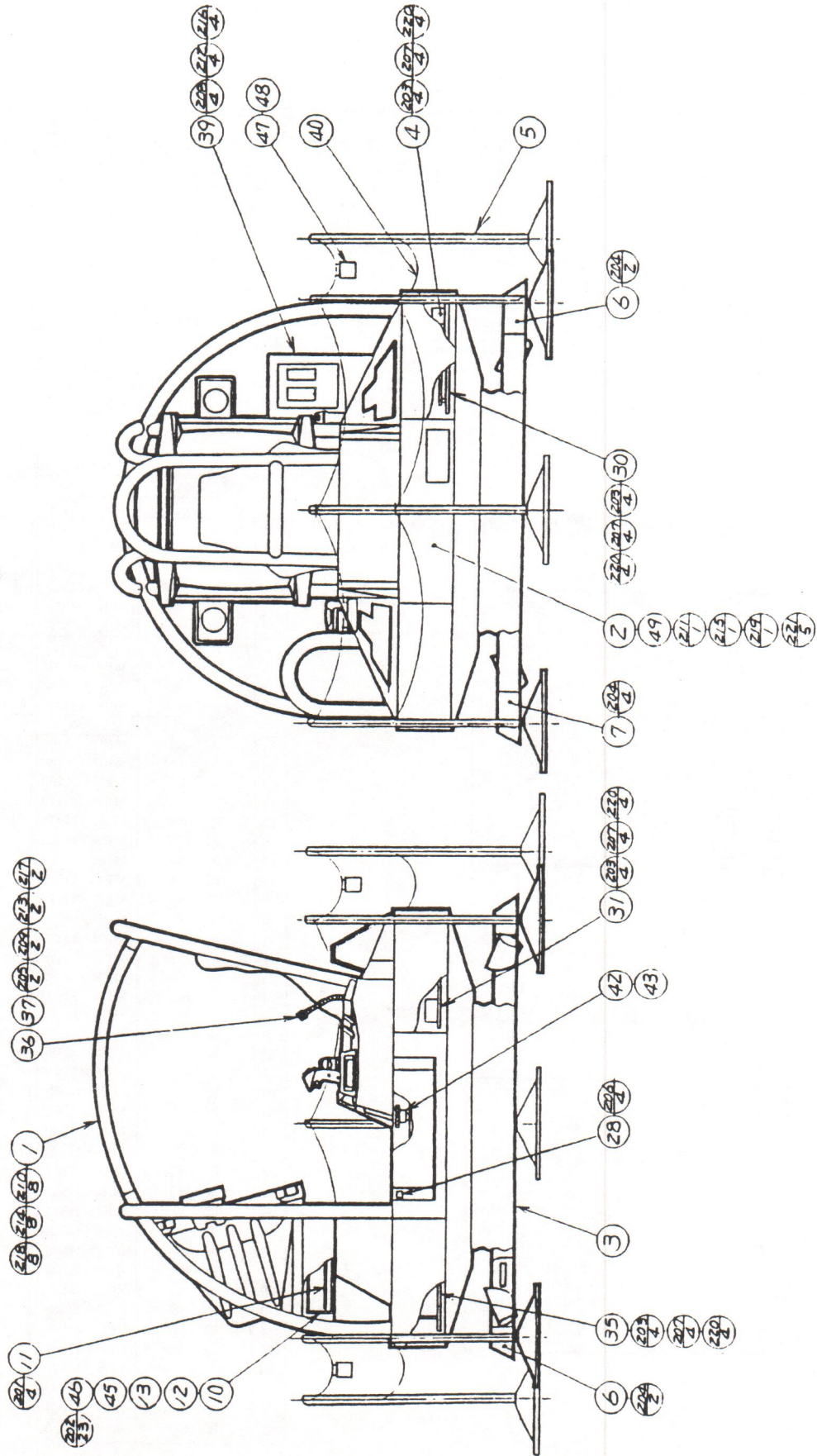



① TOP ASSY GALAXY FORCE SUPER DX (YZ-0000) (D-2/3)

ITEM NO.	PART NO.	DESCRIPTION
1	YZ-1000	ASSY TOP FRAME
2	YZ-2000	ASSY TURN TABLE
3	YZ-3000	ASSY BASE
4	YZ-4000	ASSY PWR SPLY MAIN
5	YZ-0013	ASSY POLE
6	YZ-0002	ASSY LEG COVER L
7	YZ-0003	ASSY LEG COVER R
10	YZ-0008	SHIELD BASE
11	834-6614	GAME BD GALAXY FORCE
12	839-0187	FILTER BD A
13	839-0184	FILTER BD B
14	420-5886-01	OWNERS MANUAL GALAXY FORCE SUPER DX. ENG
15	421-5800-77	ORIGINAL SEAL
16	421-7216	ADJUST INSTR SEET
20	421-6594	STICKER SERIAL NO INFO
21	421-6671	STICKER DANGER HIGH VOLTAGE
22	421-6709	STICKER SERVICE INSTR ENG
23	420-5881	DSPL MANUAL 26" 200-5112 ENG
	420-5882	DSPL MANUAL 26" 200-5125 ENG
24	SGB-1035X	KEY BAG
25	SGM-2675	POLYETHYLENE BAG 240×370
26	540-0018	DRIVER FOR TAMP PRF SCR M4
	540-0006-01	WRENCH FOR TAMP PRF SCR DUAL TYPE M4
27	540-0017	DRIVER FOR TAMP PRF SCR M5
	540-0007-01	WRENCH FOR TAMP PRF SCR DUAL TYPE M5
28	117-5111	PLATE ELEC SPEC
29	SGM-3890	POLYETHYLENE COVER
30	YZ-4100	ASSY PWR SPLY SUB
31	YZ-4200	ASSY PWR DRIVE
32	421-7217	INSTALLATION INSTR
33	220-5045-01	KEY MASTER FOR 220-5044
35	YZ-4300	ASSY SW REGU & DRIVE BD
36	YZ-0009	COLLAR
37	RH-1104	SEAT BELT
39	YZ-1200	ASSY COIN CHUTE TOWER
40	YZ-0011	CHAIN
42	601-6109	GEAR 60
43	YZ-2016	GEAR SPACER
44	540-0009-01	WRENCH FOR TAMP PRF SCR DUAL TYPE M8
45	280-5079	NYLATCH GROMMET
46	280-5080	NYLATCH PLUNGER
47	421-7054-01	CAUTION PLATE ENG
48	TX-0023-C	HOOK
49	421-6241	STICKER DAINGER ENG
201	001-0310	M SCR FH M3×10
202	010-0308-F	S-TITE SCR PH W/F M3×8
203	000-0425	M SCR PH M4×25
204	008-0510	TMP PRF SCR TH M5×10
205	039-0045	HEX BLT M10×80
206	047-0001	RVT OPEN TYPE 3.2×4.4
207	061-0004	SPR WSHR M4

## ① TOP ASSY GALAXY FORCE SUPER DX (YZ-0000)

(D-3/3)

ITEM NO.	PART NO.	DESCRIPTION
208	050-0008	HEX NUT M8
209	050-0010	HEX NUT M10
210	059-0017	HEX NUT P=1.75 M12
211	059-0016	HEX NUT M14
212	061-0008	SPR WSHR M8
213	061-0010	SPR WSHR M10
214	069-0030	SPR WSHR M12
215	069-0019	SPR WSHR M14
216	060-0008	FLT WSHR M8
217	060-0010	FLT WSHR M10
218	069-0020	FLT WSHR M12
219	069-0045	FLT WSHR M14
220	069-0007	FLT WSHR 4.4-16×1.6
221	069-0070	FLT WSHR 15.2-23×1



② ASSY LEG COVER L (YZ-0002)

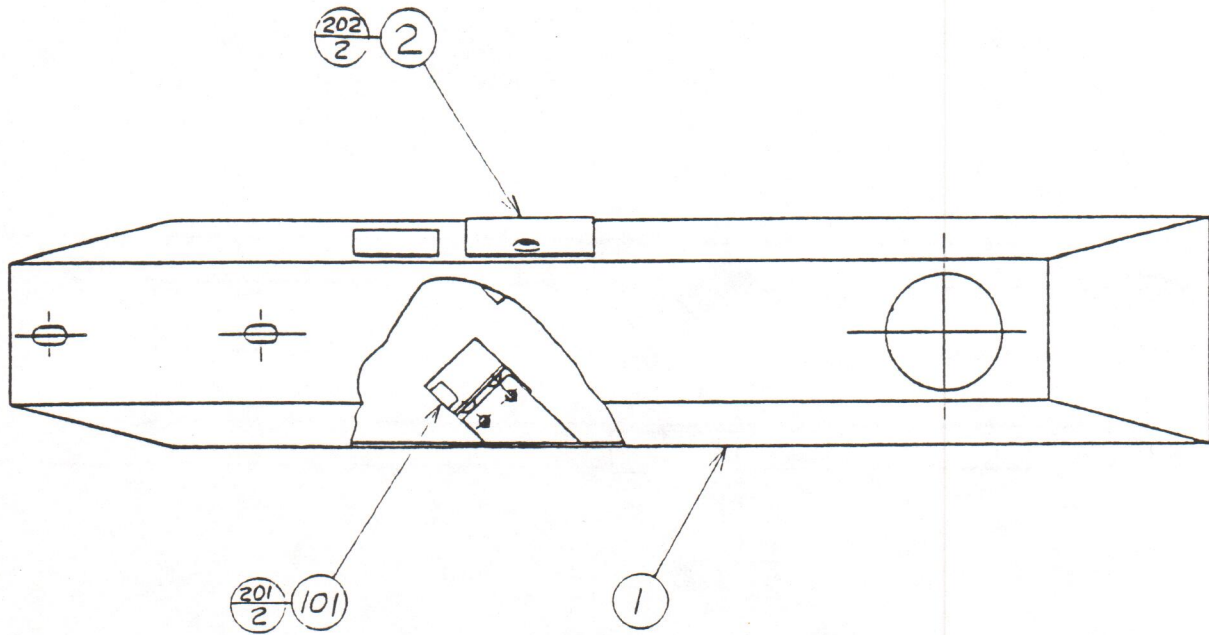

ITEM NO.	PART NO.	DESCRIPTION
1	YZ-0004	LEG COVER
2	YZ-0007	SENSOR COVER
101	370-5019-01	BEAM SENSOR
201	000-0408-FS	M SCR PH W/FS M4×8
202	008-0410	TMP PRF SCR TH M4×10

③ ASSY LEG COVER R (YZ-0003)

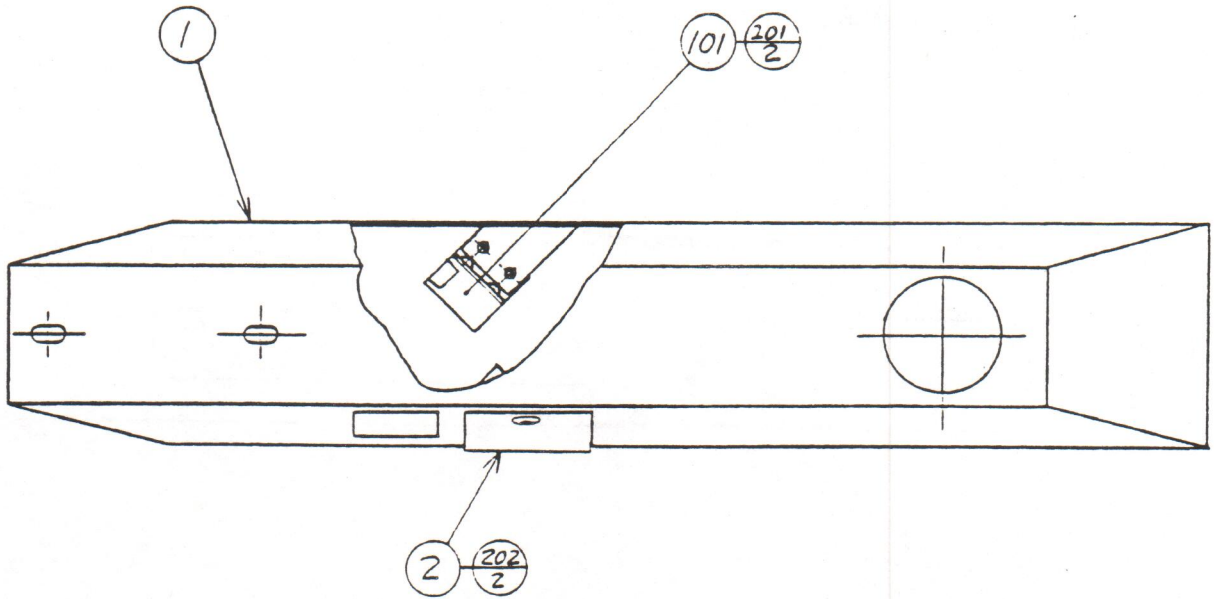

ITEM NO.	PART NO.	DESCRIPTION
1	YZ-0004	LEG COVER
2	YZ-0007	SENSOR COVER
101	370-5019-02	BEAM SENSOR
201	000-0408-FS	M SCR PH W/FS M4×8
202	008-0410	TMP PRF SCR TH M4×10



④ ASSY TOP FRAME (YZ-1000)

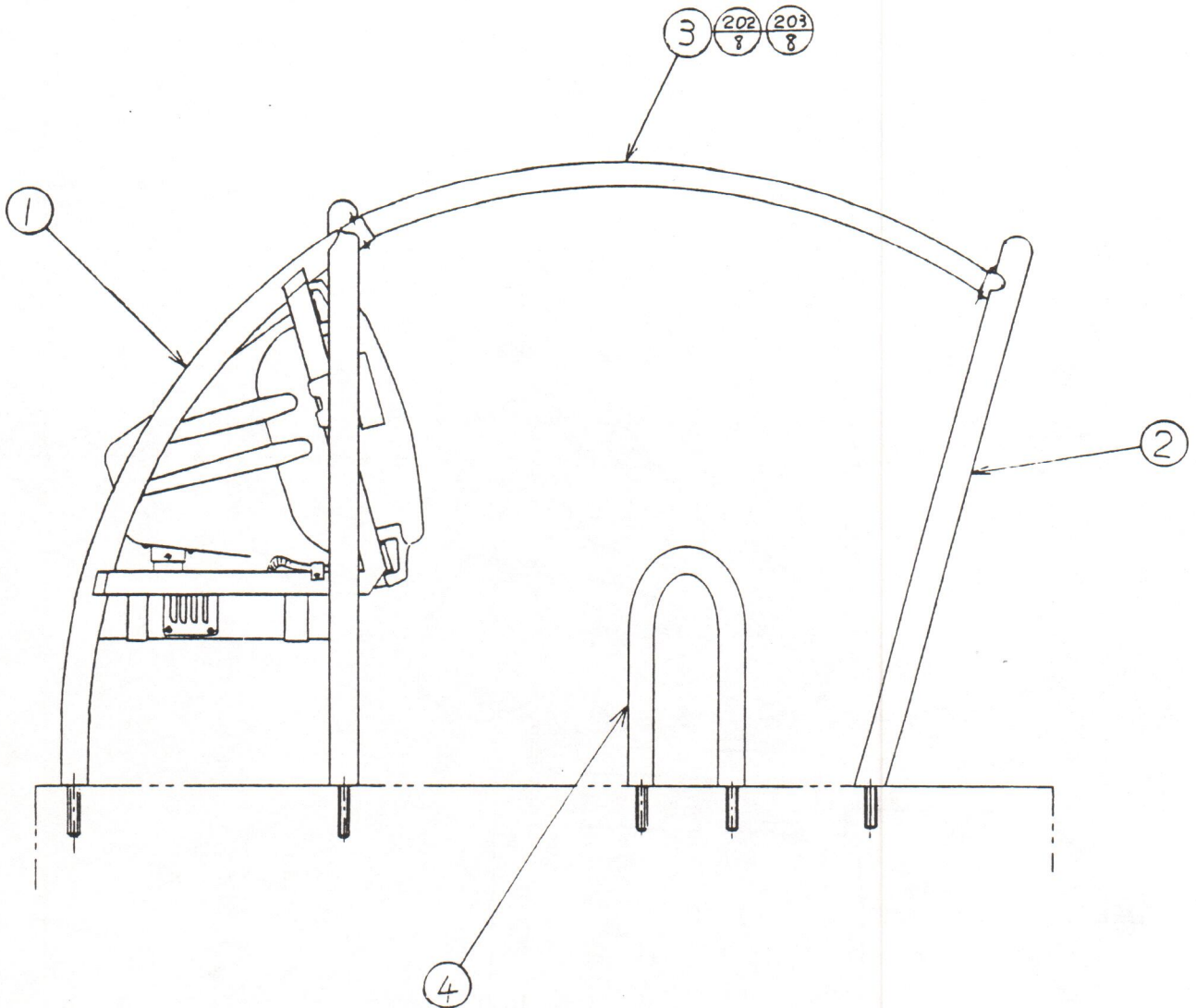

ITEM NO.	PART NO.	DESCRIPTION
1	YZ-1100	ASSY MONITOR STAND
2	YZ-1001	ROLL FOOP
3	YZ-1002	MAIN BAR
4	YZ-1003	RAIL
202	009-0812	TMP RRF SCR BH M8×25
203	069-0035	FLT WSHR BLK M8

⑤ ASSY MONITOR STAND (YZ-1100)

(D-1/2)

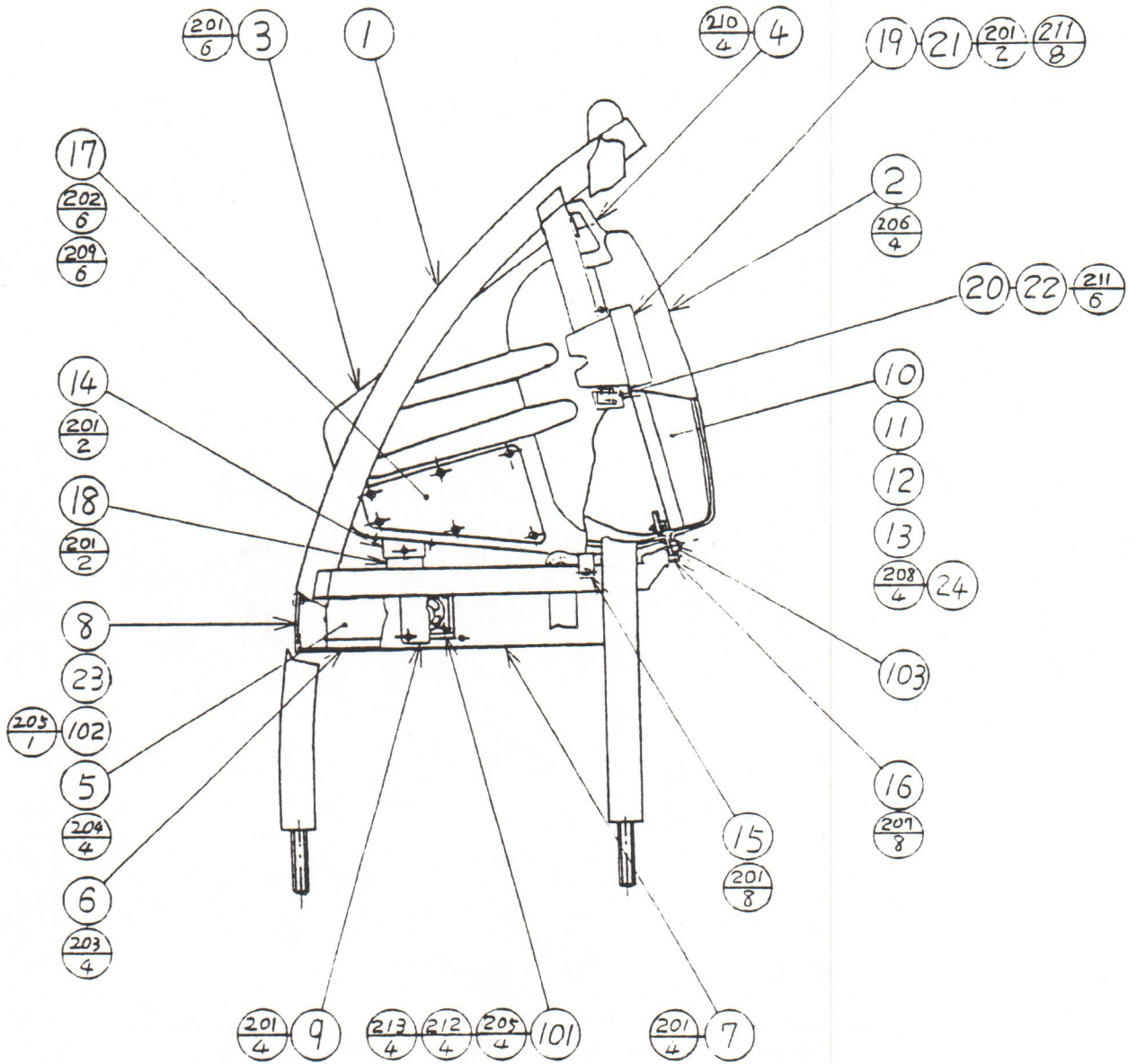



⑤ ASSY MONITOR STAND (YZ-1100)

(D-2/2)

ITEM NO.	PART NO.	DESCRIPTION
1	YZ-1101	MONITOR STAND
2	YZ-1102	SMOKED GLASS
3	YZ-1103	MONITOR COVER R
4	YZ-1104	MONITOR COVER S
5	YZ-1105	SHIELD CASE
6	YZ-1106	WOOD BASE
7	YZ-1107	SHIELD PROTECTOR
8	YZ-1108	SERVICE DOOR
9	YZ-1109	FAN COVER
10	200-5112-15	ASSY CLR DSPL 26 TYPE 15K 100V
	200-5125-15	ASSY CLR DSPL 26 TYPE 15K 100V
11	280-5112	BUSH FOR TV
12	280-5113	COLLAR FOR TV
13	280-5114	SPACER 6.4-25x2
14	YZ-1110	WIRE COVER
15	YZ-1111	TUBE HOLDER
16	YZ-1112	GLASS BRKT
17	YZ-1113	DOOR MONITOR
18	YZ-1114	WIRE COVER A
19	YZ-1300	ASSY SPEAKER BOX-L
20	YZ-1004	SPEAKER BRKT L
21	YZ-1308	ASSY SPEAKER BOX-R
22	YZ-1005	SPEAKER BRKT R
23	DP-1167	TNG LKG
101	260-0027	FAN MORTER AC 100V
201	008-0410	TMP PRF SCR TH M4x10
202	008-0416	TMP PRF SCR TH M4x16
203	008-0512	TMP PRF SCR TH M5x12
204	005-3513-F	W SCR RH W/F 3.5x13
205	000-0330	M SCR PH M3x30
206	000-0408-FS	M SCR PH W/FS M4x8
207	000-0408-S	M SCR PH W/S M4x8
208	000-0525-S	M SCR PH W/S M5 25
209	059-0014	WELL NUT M4

⑥ ASSY COIN CHUTE TOWER (YZ-1200)

(D-1/2)

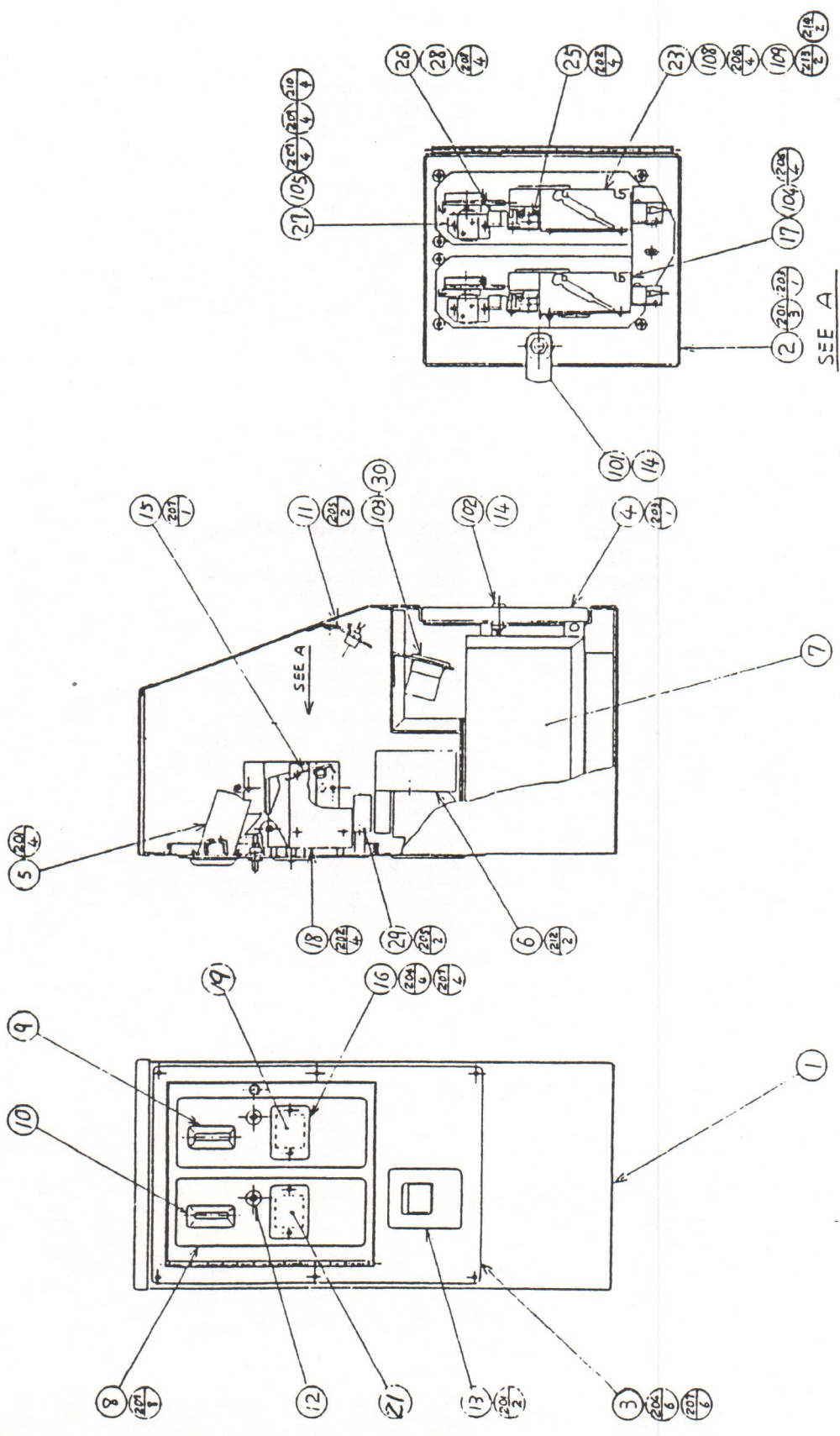



⑥ ASSY COIN CHUTE TOWER (YZ-1200)

(D-2/2)

ITEM NO.	PART NO.	DESCRIPTION
1	YZ-1201	COIN CHUTE TOWER
2	YZ-1202	COIN CHUTE DOOR
3	YZ-1203	DOOR PANEL
4	YZ-1204	DOOR CASH BOX
5	YZ-1205	COIN ENTRY CHUTE
6	YZ-1206	LOWER COIN CHUTE
7	YZ-1207	CASH BOX
8	YZ-1208	COIN ENTRY PLATE
9	220-5167	COIN ENTRY
10	220-5167	COIN ENTRY
11	TX-0104	SW UNIT
12	240-0097	ASSY REJECT BUTTON
13	220-5205	REJECT CUP & FLAP DOOR ASSY
14	DP-1167	TNG LKG
15	109-0045	HOLDER KEY TURBO UPR
16	YZ-1210	DENOMINATION PLATE
17	220-5086	COIN CHUTE BRACKET
18	HN-3002	COIN CHUTE BRACKET BASE
19	421-7220	DENOMINATION SHEET
21	421-7220	DENOMINATION SHEET
23	220-5086	COIN CHUTE BRKT
25	105-0015	BRKT REJECT LEVER
26	112-0002	LEVER REJDCT
27	YZ-1212	BLOCKER BRKT
28	123-0035	SHAFT
29	YZ-1213	REJET COIN CHUTE
30	421-6591	STICKER COIN METER
101	220-5044-01	MAGNETIC LOCK MASTER W/O KEY
102	220-5046	MAGNETIC LOCK W/KEY
103	220-5064	MAG CNTR 6DIG DC 5V
104	220-5208	COIN CHUTE REJR
105	124-5020	SOL 2WAY LACH DC 24V
106	280-5008	CORD CLAMP $\phi$ 15
107	280-0425	CORD CLAMP $\phi$ 10
108	220-5208	COIN CHUTE REJR
201	000-0306-S	M SCR PH W/S M3x6
202	000-0408-FS	M SCR PH W/FS M4x8
203	000-0430	M SCR PH M4x30
204	031-0410-B	CRG BLT BLK M4x10
205	010-0306-F	S-TITE SCR PH W/F M3x6
206	010-0406-F	S-TITE SCR PH W/F M4x6
207	051-0004	FLG NUT M4
208	069-0057	E WSHR 3.2mm
209	029-0188	M SCR PH M2.6x4
210	069-0078	SPR WSHR M2.6
212	000-0306-FS	M SCR PH W/FS M3x6

⑦ ASSY SPEAKER BOX-L (YZ-1300)

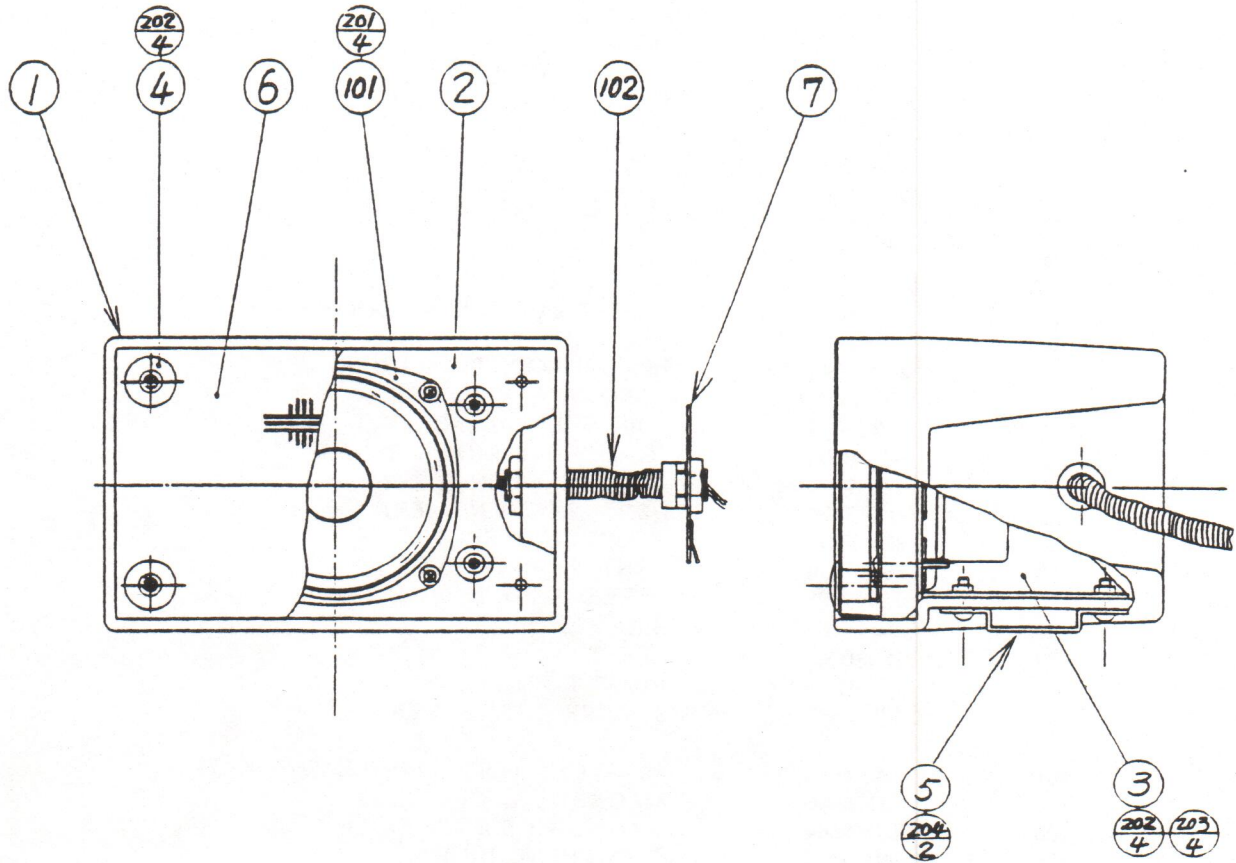

ITEM NO.	PART NO.	EDSCRIPTION
1	YZ-1301	SPEAKER BOX-L
2	YZ-1302	BAFFLE BOARD
3	YZ-1303	SPEAKER BASE
4	YZ-1304	COLLAR
5	YZ-1305	SPACER BRKT
6	YZ-1306	SP GUARDE NET
7	YZ-1307	TUBE BRKT
101	130-5029	SPEAKER 8 OHM 15W 10cm
102	310-5026	FLEX TUBE $\varnothing$ 10
201	029-0059	W SCR RH BLK W/F 3.5×16
202	008-0430	TMP PRF SCR TH M4×30
203	069-0055	FLT WSHR SPECIAL BLK 4.4-16×1.6
204	008-0516	TMP PRF SCR TH M5×16



⑧ ASSY SPEAKER BOX-R (YZ-1308)

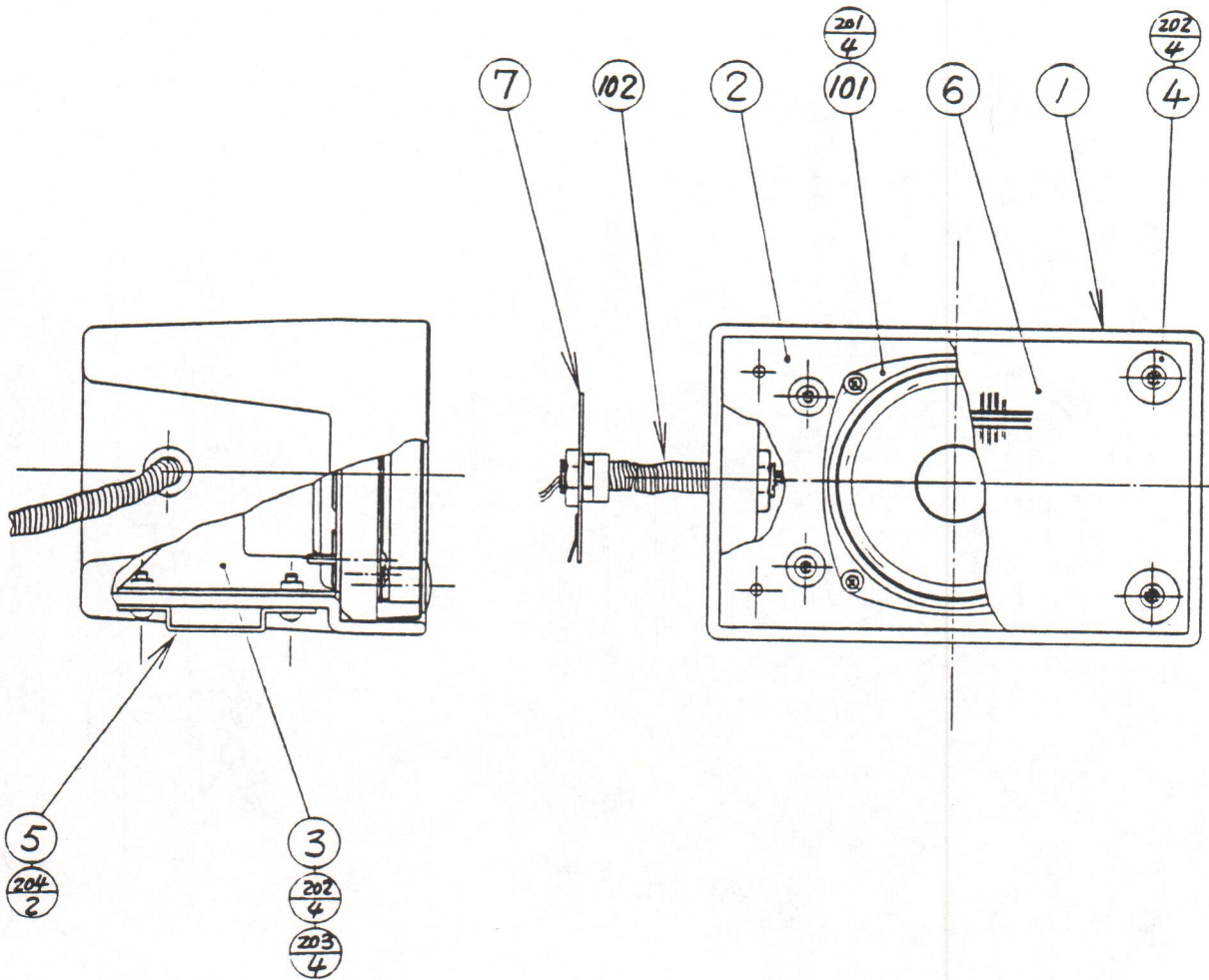

ITEM NO.	PART NO.	DESCRIPTION
1	YZ-1309	SPEAKER BOX-R
2	YZ-1302	BAFFLE BOARD
3	YZ-1303	SPEAKER BASE
4	YZ-1304	COLLAR
5	YZ-1305	SPACER BRKT
6	YZ-1306	SP GUARDE NET
7	YZ-1307	TUBE BRKT
101	130-5029	SPEAKER 8 OHM 15W 10cm
102	310-5026	FLEX TUBE $\varnothing$ 10
201	029-0059	W SCR RH BLK W/F 3.5x16
202	008-0430	TMP PRF SCR TH M4x30
203	069-0055	FLT WSHR SPECIAL BLK 4.4-16x1.6
204	008-0516	TMP PRF SCR TH M5x16

9 ASSY TURN TABLE (YZ-2000)

(D-1/3)

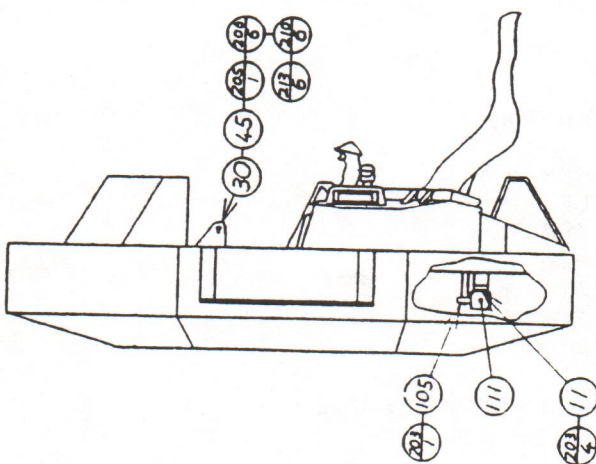
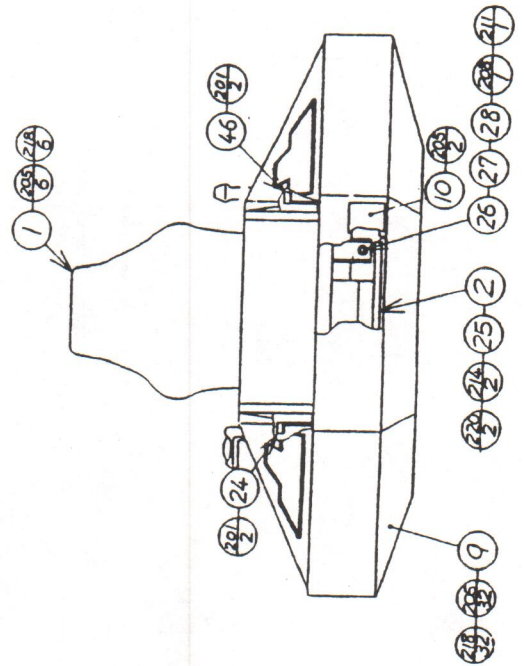
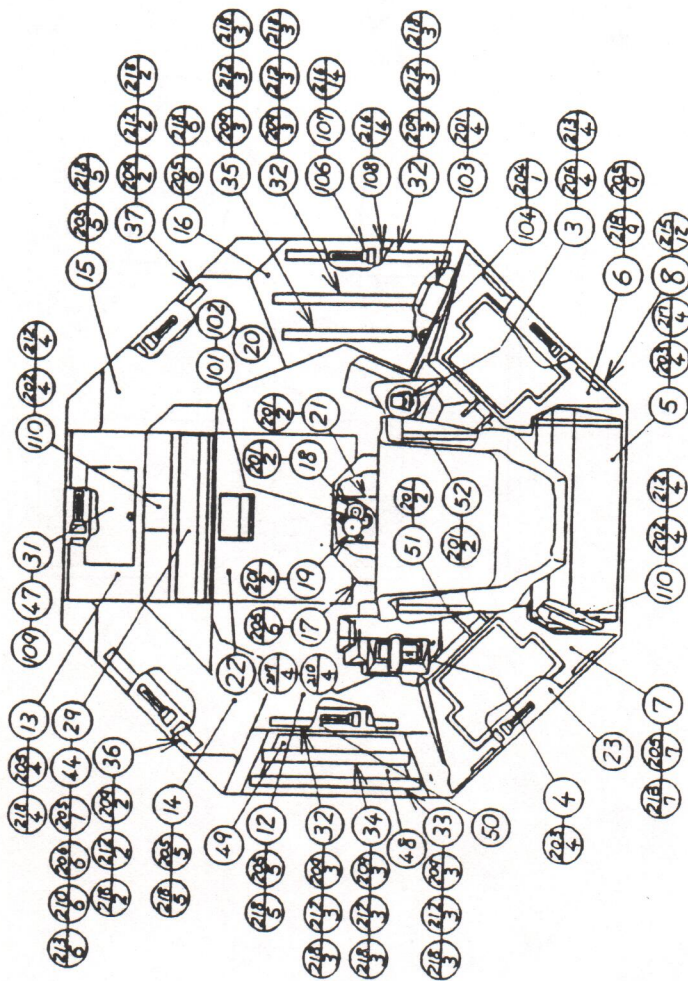



⑨ ASSY TURN TABLE (YZ-2000)

(D-2/3)

ITEM NO.	PART NO.	DESCRIPTION
1	YZ-2100	ASSY BUCKET SEAT
2	YZ-2200	MOTOR UNIT-T
3	YZ-2300	CONTROL UNIT
4	YZ-2400	THROTTLE UNIT
5	YZ-2500	BILL BOARD
6	YZ-2600	ASSY CONT COVER
7	YZ-2700	ASSY THROTTLE COVER
8	YZ-2001	TURN TABLE
9	YZ-2002	UNDER PANEL
10	YZ-2003	MAINTENANCE DOOR
11	YZ-2004	SW. STOPPER
12	YZ-2005	COVER LEFT
13	YZ-2006	FOOT COVER-F
14	YZ-2007	FOOT COVER-L
15	YZ-2008	FOOT COVER-R
16	YZ-2009	COVER RIGHT
17	YZ-2010	VR. COVER
18	YZ-2011	IDLE GEAR UNIT
19	YZ-2014	TURN VR. UNIT
21	YZ-2017	GEAR PROTECTOR
22	YZ-2018	FLOOR PANEL
23	YZ-2019	REFLECTOR A
24	YZ-2020	HOLD BRACKET L
25	TX-2016	MOUNT SCREW
26	TX-2017	COMP SPRING
27	TX-2018	SPRING GUIDE
28	TX-3029	SPACER RING
29	YZ-2021	FOOT REST BRKT L
30	YZ-2022	FOOT REST BRKT S
31	YZ-2023	SERVISE DOOR
32	YZ-2024	CORD SW. A
33	YZ-2025	CORD SW. B
34	YZ-2026	CORD SW. C
35	YZ-2027	CORD SW. D
36	YZ-2028	CORD SW. E
37	YZ-2029	CORD SW. F
44	YZ-2036	FOOT REST BAR L
45	YZ-2037	FOOT REST BAR S
46	YZ-2038	HOLD BRACKET R
47	DP-1167	TNG LKG
48	YZ-2040	FLOOR MAT B
49	YZ-2041	FLOOR MAT C
50	YZ-2044	REFLECTOR B
51	YZ-2045	BLIND L
52	YZ-2046	BLIND R
53	YZ-2047	MOUNT SCREW S
101	100-5063	BEARING $\phi$ 25
102	100-5071	BEARING $\phi$ 30
103	260-0023	FAN MOTOR AC 100V
104	117-0184	TERMINAL PLATE 1L4P
105	601-5861	RUBBER WHEEL $\phi$ 75
106	390-5223	FL 9W BLUE (DELUX-S9W BLUE)
107	214-0125	SOCKET FOR DULX (G-23)
108	182-5027	COIL BLST FOR DULX 9W
109	220-5234	MAGNETIC LOCK MASTER W/O KEY

⑨ ASSY TURN TABLE (YZ-2000)

(D-3/3)

ITEM NO.	PART NO.	DESCRIPTION
110	260-0011-02	AXIAL FLOW FAN AC 100V 50-60Hz
111	509-5236	MAT SW. □50
201	000-0410-SF	M. SCR PH W/SF M4×10
202	000-0450	M. SCR PH M4×50
203	000-0510-SF	M. SCR PH W/SF M5×10
204	000-0310-SF	M. SCR PH W/SF M3×10
205	008-0410	TMP PRF SCR TH M4×10
206	030-0820-B	HEX BLT BLK M8×20
207	030-0830-B	HEX BLK M8×30
208	039-0033	HEX BLT BLK M10×90
209	050-0004	HEX NUT M4
210	060-0008-B	FLT WSHR BLK M8
211	060-0010	FLT WSHR M10
212	061-0004	SPR WSHR M4
213	061-0008-B	SPR WSHR BLK M8
214	061-0010	SPR WSHR M10
215	010-0310-F	S-TITE SCR W/F M3×10
216	010-0408-F	S-TITE SCR W/F M4×8
217	069-0001	FLT WSHR 5.5-20×1.6
218	069-0055	FLT WSHR SPECIA BLK 4.4-16×1.6
220	050-0010	HEX NUT M10



# ⑩ MOTOR UNIT T (YZ-2200)

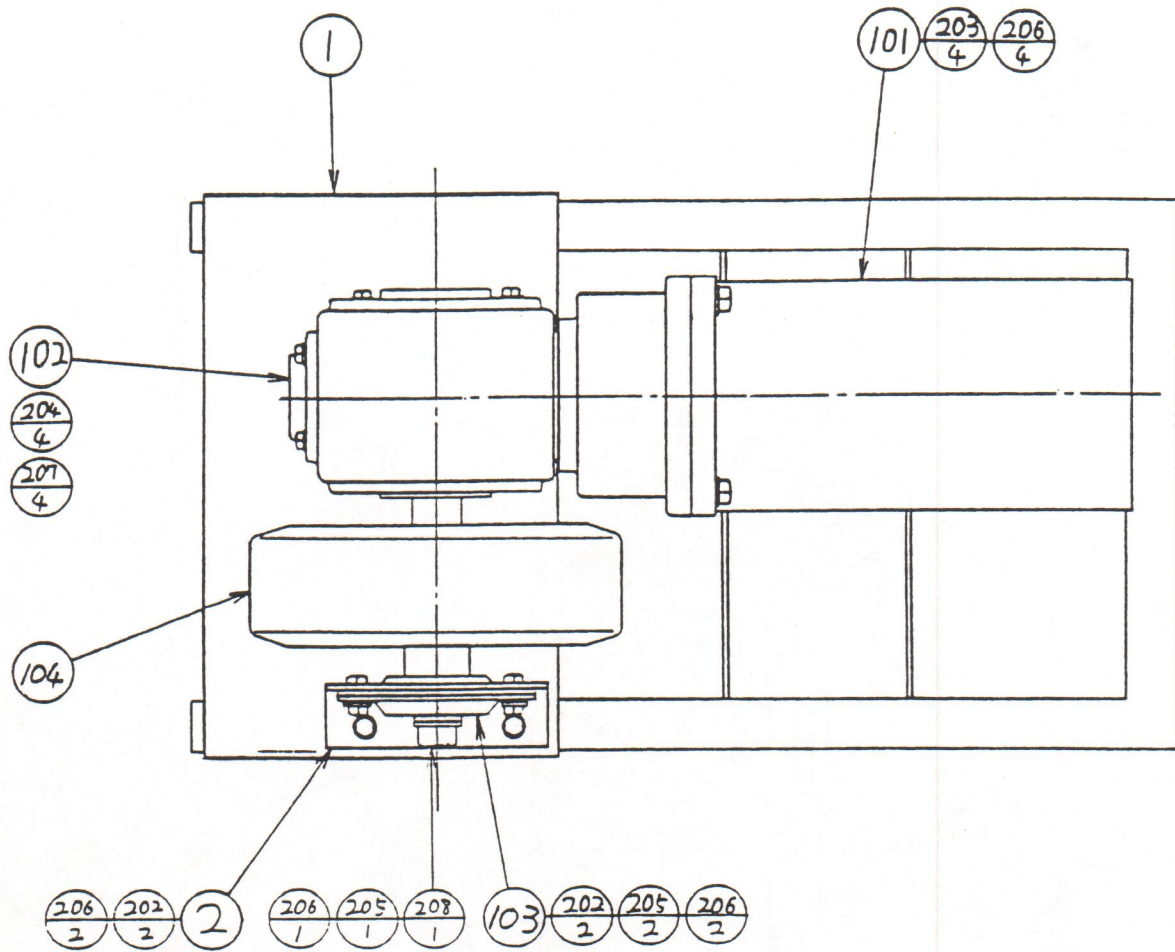

ITEM NO.	PART NO.	DESCRIPTION
1	TX-2032	MOTOR BASE
2	TX-2033	PILLOW BRACKET
101	350-5133	MOTOR DC 80V W/ENCODER
102	350-5135	WORM SPEED REDUCER 1/40
103	100-5045	BEARING $\phi$ 15
104	601-6113	RUBBE WHEEL
202	030-0620	HEX BLT M6×20
203	029-0075	M. SCR PH M6×25
204	030-0820	HEX BLT M8×20
205	060-0006	FLT WSHR M6
206	061-0006	SPR WSHR M6
207	061-0008	SPR WSHR M8
208	029-0166	M. SCR PH M6×10

11 CONTROL UNIT (YZ-2300)

(D-1/2)

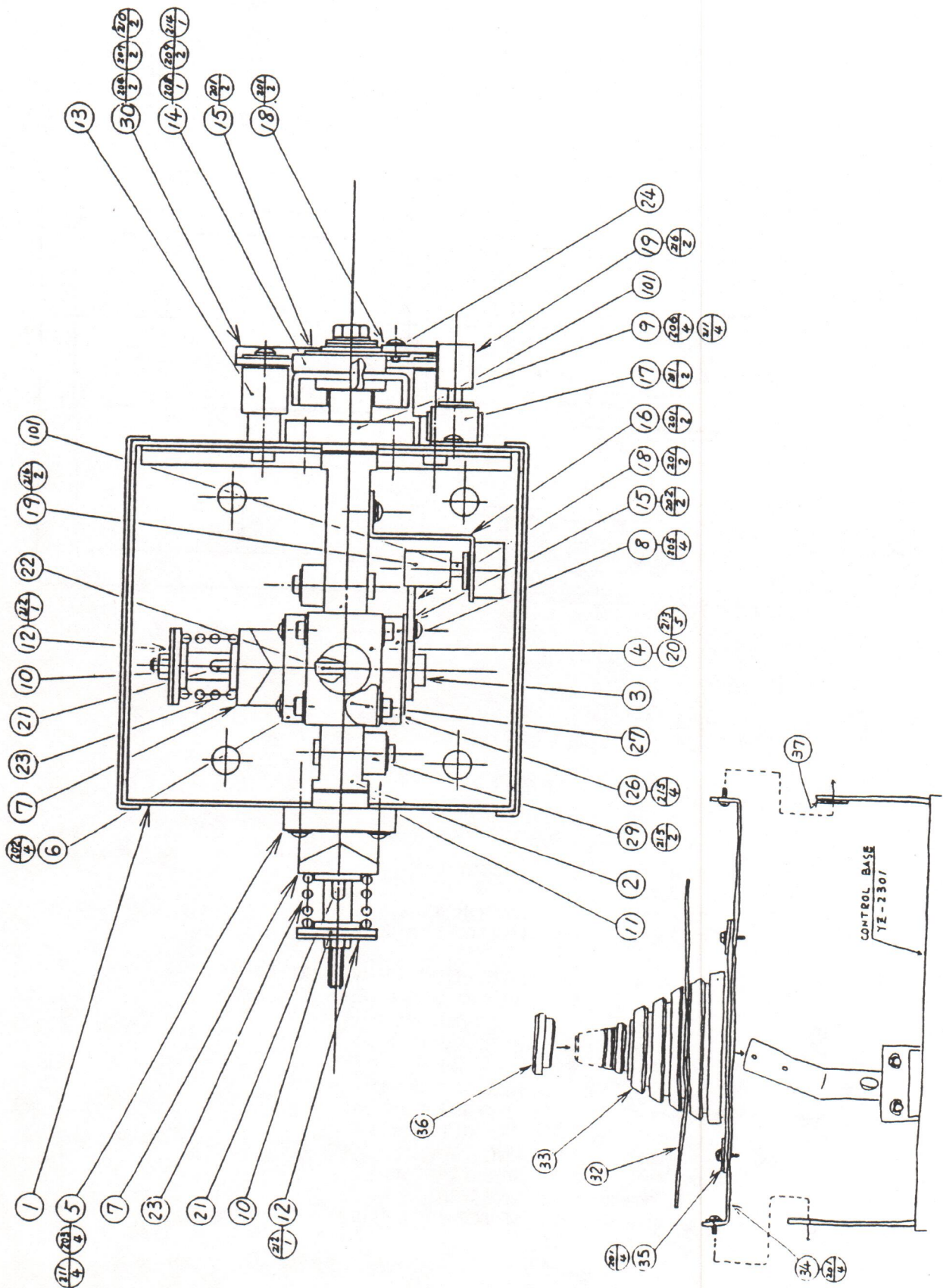



⑪ CONTROL UNIT (YZ-2300)

(D-2/2)

ITEM NO.	PART NO.	DESCRIPTION
1	YZ-2301	CONTROL BASE
2	YZ-2302	CENTER SHAFT
3	YZ-2303	INNER SHAFT
4	YZ-2304	HANDLE SHAFT
5	YZ-2305	PRIMARY CAM-R
6	YZ-2306	PRIMARY CAM-P
7	YZ-2307	SLIDING CAM
8	YZ-2308	RIGHT BEARING
9	YZ-2309	FRONT BEARING
10	YZ-2310	GUIDE RING
11	YZ-2311	SPACER $\phi$ 18
12	YZ-2312	PRESS RING
13	YZ-2313	STOPPER RUBBER $\phi$ 10
14	YZ-2314	STOPPER ARM
15	YZ-2315	ADJUST PLATE
16	YZ-2316	VR BRACKET-P
17	YZ-2317	VR BRACKET-R
18	601-6126	GEAR 1/4 (100)
19	601-5943	GEAR 20 $\phi$ 15
20	YZ-2329	ASSY HANDLE GRIP
21	YZ-2318	KEY 5x5x20
22	YZ-2319	KEY 5x5x16
23	YZ-2320	COMPRESSION SPRING
24	KR-1122	KEY A
26	YZ-2322	JOINT SHAFT
27	YZ-2323	STOPPER RUBBER $\phi$ 8
28	YZ-2324	H. ADJUST RING
29	YZ-2325	ASSISTANT STOPPER RUBBER
30	YZ-2326	S. JOINT BRKT
32	YZ-2328	BLIND SHEET
33	YZ-2330X	SHIFT BOOT
34	YZ-2331	BRACKET BOOT
35	YZ-2332	SUPPORT BRACKET
36	YZ-2333	STOPPER
37	YZ-2334	SPACER
101	220-5130	VOL CONT B-5K OHM
201	000-0410-FS	M SCR PH W/FS M4x10
202	000-0418-FS	M SCR PH W/FS M4x18
203	000-0420-FS	M SCR PH W/FS M4x20
204	000-0512	M SCR PH M5x12
205	001-0414	M SCR FH M4x14
206	001-0420	M SCR FH M4x20
207	069-0001	FLT WSHR 5.5-20x1.6
208	061-0008	SPR WSHR M8
209	069-0058	FLT WSHR 8.5-22x1.6
210	061-0005	SPR WSHR M5
211	054-0004	U-NUT M4
212	054-0006	U-NUT M6
213	029-0052	TMP PRF SCR PH SPECIAL M5x10
214	030-0820	HEX BLT M8x20
215	065-0007	E RING 7mm
216	028-0003	SET SCR PH SPCL M3x8
217	028-0023	SET SCR HEX SKT CUP POINT M4x6

12 THROTTLE UNIT (YZ-2400)

(D-1/2)

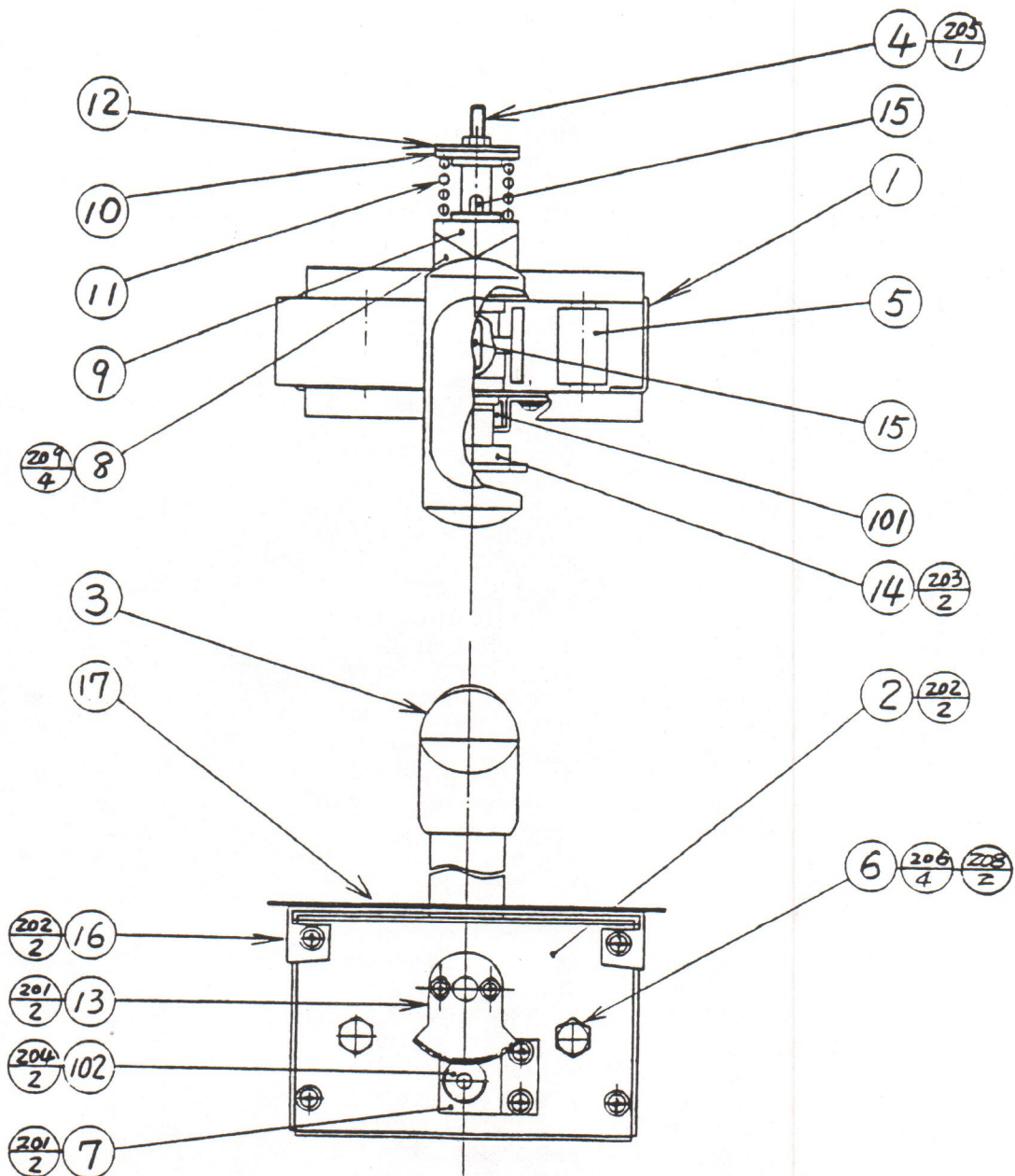



⑫ THROTTLE UNIT (YZ-2400)

(D-2/2)

ITEM NO.	PART NO.	DESCRIPTION
1	YZ-2401	THROTTLE FRAME
2	YZ-2402	THROTTLE LID
3	YZ-2403	THROTTLE LEVER
4	YZ-2404	THROTTLE SHAFT
5	YZ-2405	LEVER STOPPER
6	YZ-2406	SHOLDER SCREW
7	YZ-2407	VR. BRKT
8	YZ-2306	PRIMARY CAM-P
9	YZ-2307	SLIDING CAM
10	YZ-2310	GUIDE RING
11	YZ-2320	COMPRESSION SPRING
12	YZ-2312	PRESS RING
13	601-6005	ADJUST GEAR
14	J1-3113	GUIDE RING
15	YZ-2318	KEY 5×5×20
16	YZ-2408	THROTTLE SLIDE BASE
17	YZ-2409	THROTTLE LEVER PLATE
101	220-5130	VOL CONT B-5K OHM
102	601-5415	GEAR 20
201	000-0408-FS	M SCR PH W/FS M4×8
202	000-0404-FS	M SCR PH W/FS M4×14
203	028-0021	SET SCR PH SPECIAL M4×16
204	028-0014	SET SCR HEX SKT M4×4
205	054-0006	U-NUT M6
206	050-0008	HEX NUT M8
208	060-0008	FLT WSHR M8
209	000-0418-FS	M SCR PH W/FS M4×18

13 ASSY CONTROL COVER (YZ-2600)

(D-1/2)

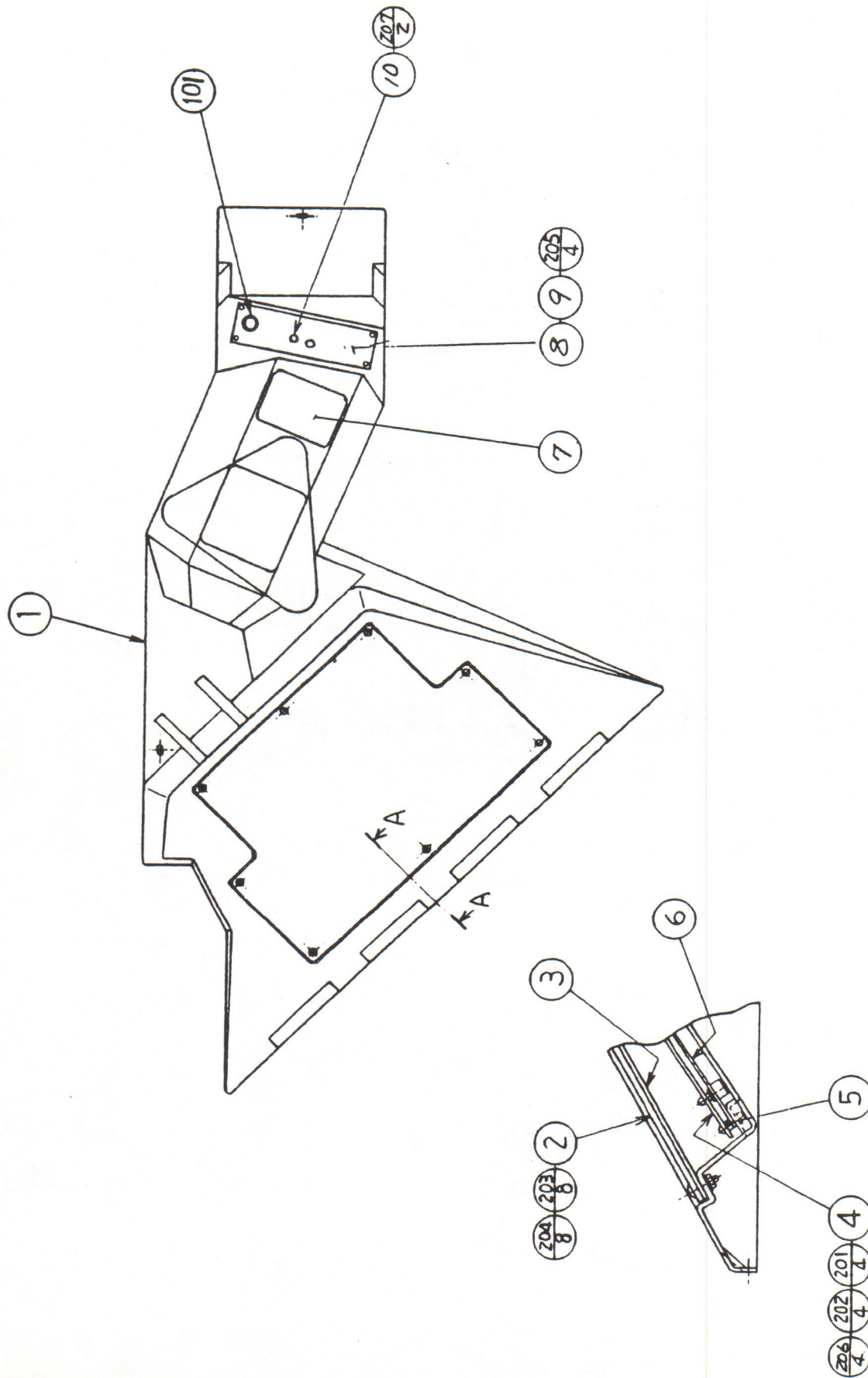

SECTION A-A



⑬ ASSY CONTROL COVER (YZ-2600)

(D-2/2)

ITEM NO.	PART NO.	DESCRIPTION
1	YZ-2601	CONTROL COVER
2	YZ-2602	ACRYL PLATE
3	YZ-2603	LENS PLATE
4	YZ-2604	MIRROR PLATE
5	280-5120	SPACER 5
6	839-0183	ASSY LAMP BD
7	422-0243-01	PLAY INSTR PLATE GALAXY FORCE ENG
8	YZ-2605	BRACKET JACK
9	YZ-2606	SW PLATE
10	839-0158	MINI JACK BD
101	509-5218	PUSH BTN SW 1T YELLOW W/LAMP
201	000-0320	M SCR PH M3×20
202	051-0003	FLG NUT M3
203	031-0420-B	CRG BLT BLK M4×20
204	051-0004	FLG NUT M4
205	008-0416	TMP PRF SCR TH M4×16
206	050-0003	HEX NUT M3
207	000-0316-FS	M SCR PH W/FS M3×16

⑭ ASSY THROTTLE COVER (YZ-2700)

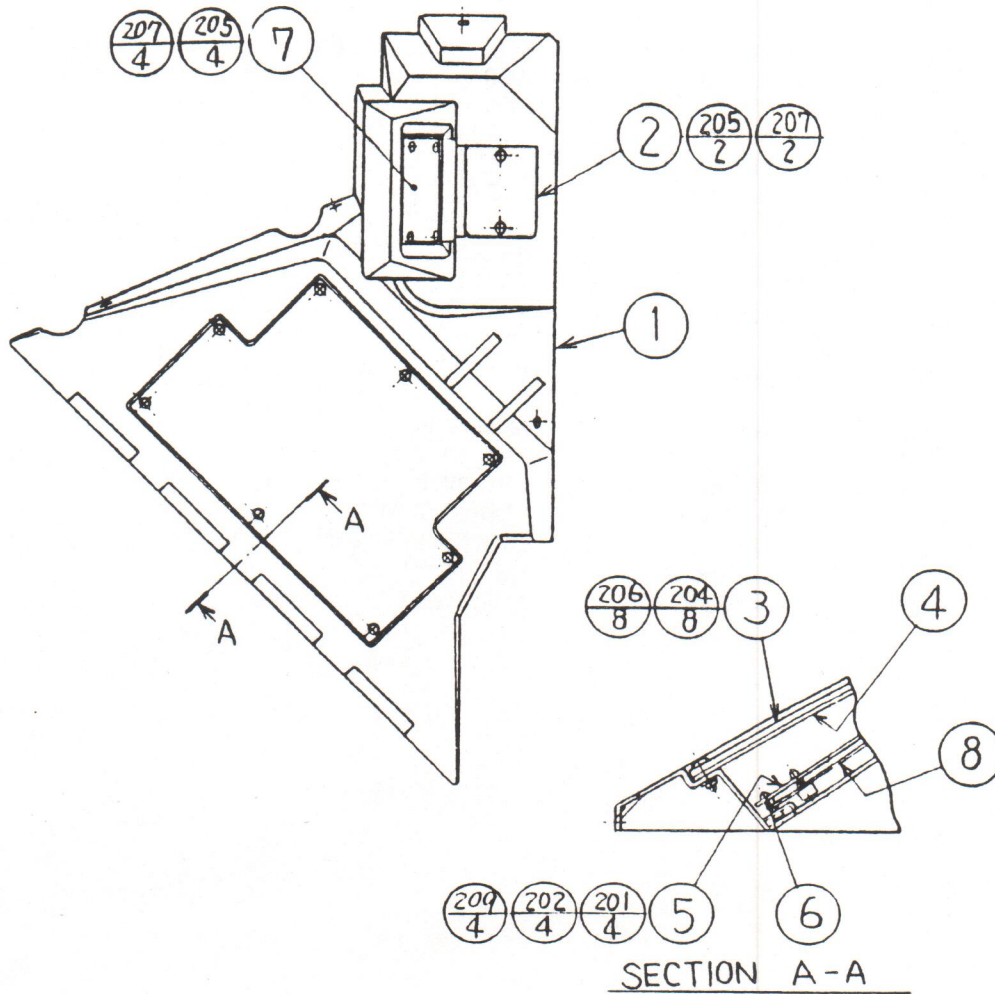

ITEM NO.	PART NO.	DESCRIPTION
1	YZ-2701	THROTTLE COVER
2	YZ-2702	COVER PLATE
3	YZ-2602	ACRYL PLATE
4	YZ-2603	LENS PLATE
5	YZ-2604	MIRROR PLATE
6	280-5120	SPACER 5
7	YZ-2703	THROTTLE PLATE
8	839-0183	ASSY LAMP BD
9	YZ-2704	PLATE BASE
201	000-0320	M SCR PH M3×20
202	051-0003	FLG NUT M3
204	031-0420-B	CRG BLT BLK M4×20
205	029-0138	TAP PRF SCR M4×16
206	051-0004	FLG NUT M4
207	059-0014	WELL NUT M4
209	050-0003	HEX NUT M3



15 ASSY BASE (YZ-3000)

(D-1/3)

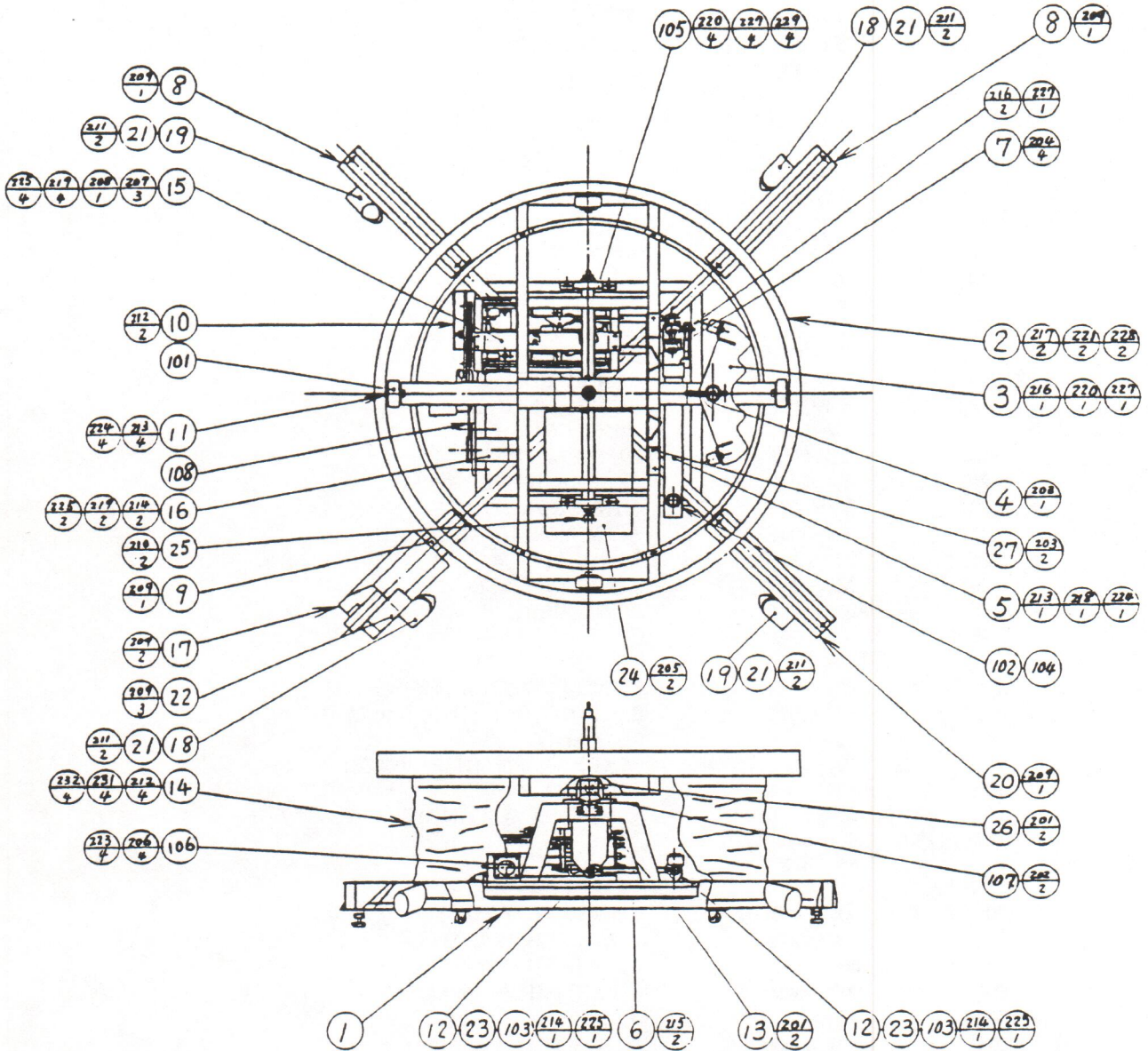

⑮ ASSY BASE (YZ-3000)

(D-2/3)

ITEM NO.	PART NO.	DESCRIPTION
1	YZ-3001	BASE
2	YZ-3002	BANK FRAME
3	YZ-3003	ASSY STOPPER
4	YZ-3006	STOPPER SPR.
5	YZ-3007	SWING ARM
6	YZ-3008	CON ROD
7	YZ-3009	GUIDE BLOCK
8	YZ-3010	WIRE COVER-A
9	YZ-3011	WIRE COVER-B
10	YZ-3012	DISC COVER
11	YZ-3013	ROLLER SHAFT
12	YZ-3014	COLLAR
13	YZ-3015	BNK VR UNIT
14	YZ-3017	ASSY BELLOW
15	YZ-3100	MECHANISM UNIT
16	YZ-3200	ASSY MOTOR
17	YZ-3300	AC UNIT
18	YZ-3021	FLASH UNIT A
19	YZ-3025	FLASH UNIT B
20	YZ-3027	WIRE COVER C
21	YZ-3028	NUT PLATE
22	YZ-3029	SPACER BRKT
23	YZ-3030	SHOULDER SCREW
24	YZ-3031	ASSY TERMINAL BOARD
25	MX-2017	ADJUSTER
26	MX-2055	ADJUST PLATE
27	YZ-3034	WALL WIRE
28	YZ-3035	COVER
101	601-6129	RUBBER WHEEL $\phi$ 75
102	100-5070	BEARING $\phi$ 15 (NSK 6002ZZ)
103	111-0006	ROD END
104	100-5063	BEARING $\phi$ 25 (NSK 6006ZZ)
105	100-5044	BEARING $\phi$ 30
106	260-0011-02	AXIAL FLOW FAN AC 100V 50-60Hz
107	601-5423	GEAR 1/6
108	350-5137	V BELT
201	000-0410-SF	M. SCR PH W/SF M4 $\times$ 10
202	000-0408-S	M. SCR PH W/S M4 $\times$ 8
203	000-0510-SF	M. SCR PH W/SF M5 $\times$ 10
204	000-0530-SF	M. SCR PH W/SF M5 $\times$ 30
205	000-0420	M. SCR PH M4 $\times$ 20
206	000-0450	M. SCR PH M4 $\times$ 50
207	039-0045	HEX BLT M10 $\times$ 80
208	039-0033	HEX BLT BLK M10 $\times$ 90
209	008-0510	TMP PRF SCR TH M5 $\times$ 10
210	028-0021	SET SCR PH SPCL M4 $\times$ 14
211	032-0410	WING BLT M4 $\times$ 10
212	032-0510	WING BLT M5 $\times$ 10
213	050-0008	HEX NUT M8
214	050-0010	HEX NUT M10
215	059-0017	HEX NUT M12
216	059-0016	HEX NUT M14
217	059-0022	HEX NUT M16
218	060-0008	FLT WSHR M8



⑮ ASSY BASE (YZ-3000)

(D-3/3)

ITEM NO.	PART NO.	DESCRIPTION
219	060-0010	FLT WSHR M10
220	069-0045	FLT WSHR M14
221	069-0075	FLT WSHR SPCL 17-35×2.3
223	061-0004	SPR WSHR M4
224	061-0008	SPR WSHR M8
225	061-0010	SPR WSHR M10
227	069-0019	SPR WSHR M14
228	069-0060	SPR WSHR M16
229	039-0036	HEX BLT S=30 M14×90
230	069-0007	FLT WSHR 4.4-16×1.6
231	061-0005	SPR WSHR M5
232	069-0001	FLT WSHR 5.5-20×1.6
233	000-0310F	M. SCR PH W/F M3×10

16 MECHANISM UNIT (YZ-3100)

(D-1/2)

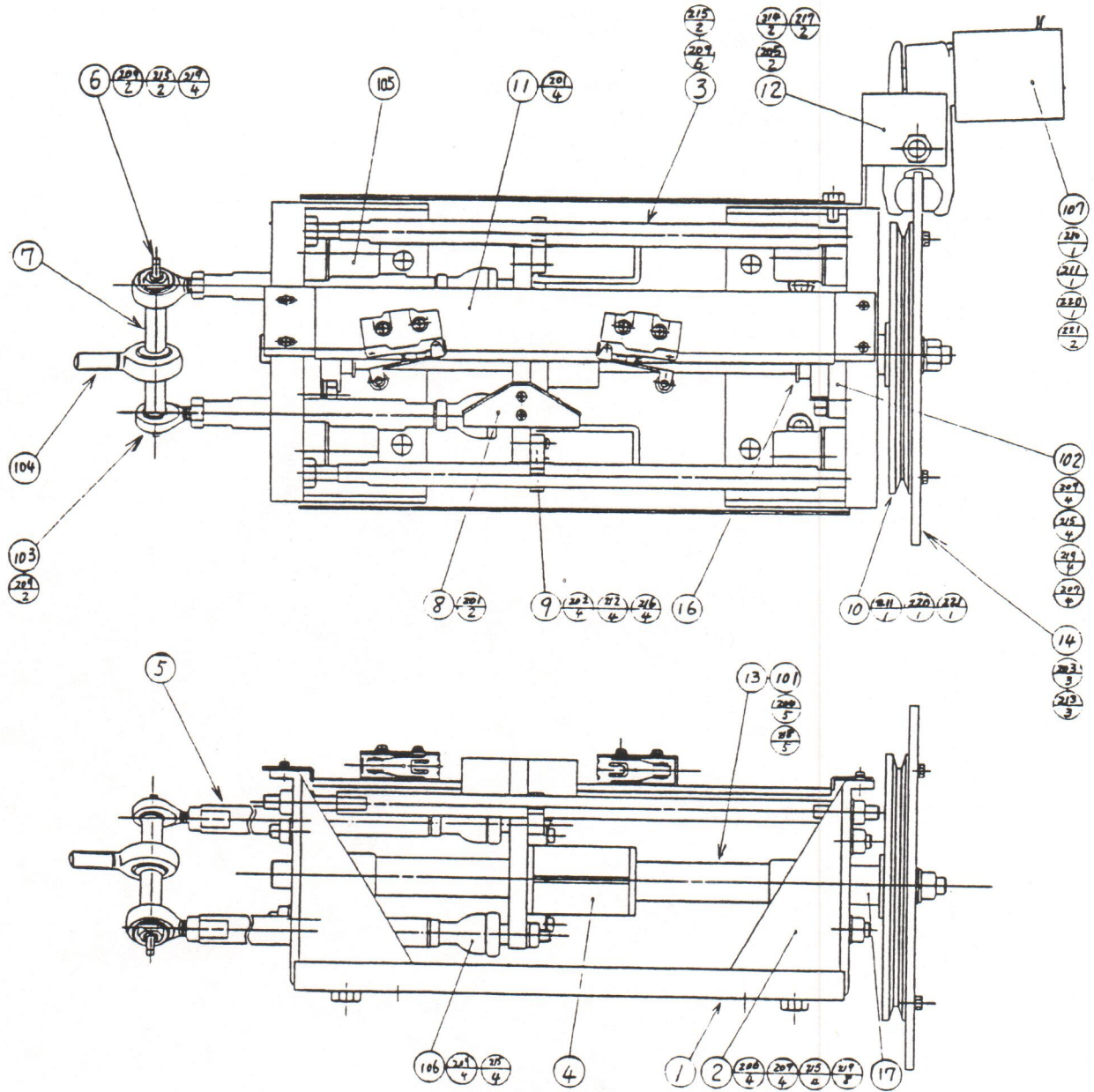



①⑥ MECHANISM UNIT (YZ-3100)

(D-2/2)

ITEM NO.	PART NO.	DESCRIPTION
1	YZ-3101	MECHA BASE
2	YZ-3102	SIDE PLATE
3	YZ-3103	ADJUST SHAFT
4	YZ-3104	MOVING PLATE
5	YZ-3105	PARALLEL ROD
6	YZ-3106	JOINT SHAFT
7	YZ-3107	J. SHAFT COLLAR
8	YZ-3108	ACTUATER
9	YZ-3109	SHAFT GUIDE
10	YZ-3110	DRIVEN PULLEY
11	YZ-3111	LIMIT SW ASSY
12	YZ-3112	CALLIPER BRACKET
13	RH-3311	KEY
14	YZ-3113	DISK PLATE
15	YZ-3114	ADJUST RING
16	RH-3313	BEARING SPACER
17	YZ-3116	THRUST COLLAR
101	350-5081	BALL SCREW
102	100-5025	BEARING UNIT
103	111-0010	ROD END $\varnothing$ 10
104	111-0012	ROD END $\varnothing$ 14
105	601-5472	RUBBER STOPPER
106	111-0013	LINK BALL
107	610-0219	BRAKE CALLIPER UNIT
201	000-0412-FS	M SCR PH W/FS M4×12
202	000-0430	M SCR PH M4×30
203	030-0525	HEX BLT M5×25
204	030-0630	HEX BLT M6×30
205	039-0032	HEX BLT M8×16
206	039-0021	HEX BLT M10×25
207	039-0013	HEX BLT M10×40
208	050-0008	HEX NUT M8
209	050-0010	HEX NUT M10
210	039-0054	HEX BOLT M12×90
211	059-0017	HEX NUT M12
212	061-0004	SPR WSHR M4
213	061-0005	SPR WSHR M5
214	061-0008	SPR WSHR M8
215	061-0010	SPR WSHR M10
216	060-0004	FLT WSHR M4
217	060-0008	FLT WSHR M8
218	061-0006	SPR WSHR M6
219	060-0010	FLT WSHR M10
220	061-0012	SPR WSHR M12
221	069-0020	FLT WSHR M12

①⑦ ASSY LIMIT SW (YZ-3111)

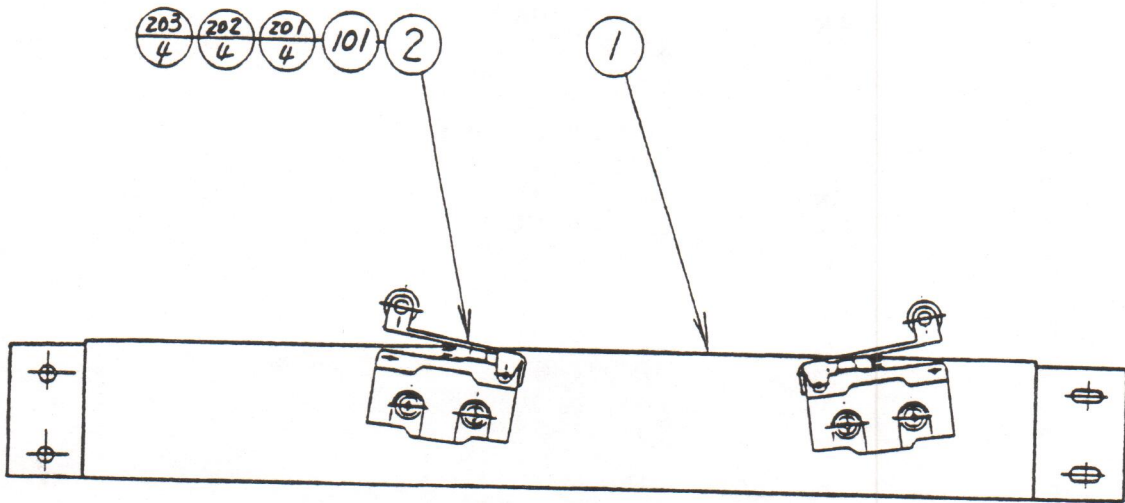

ITEM NO.	PART NO.	DESCRIPTION
1	YZ-3115	LIMIT SW BRACKET
2	KR-3023	LIMIT SW NUT PLATE
101	509-5199	SW MICRO TYPE
201	000-0430	M. SCR P.H M4×30
202	060-0004	FLT WSHR M4
203	061-0004	SPR WSHR M4



⑱ ASSY MOTOR (YZ-3200)

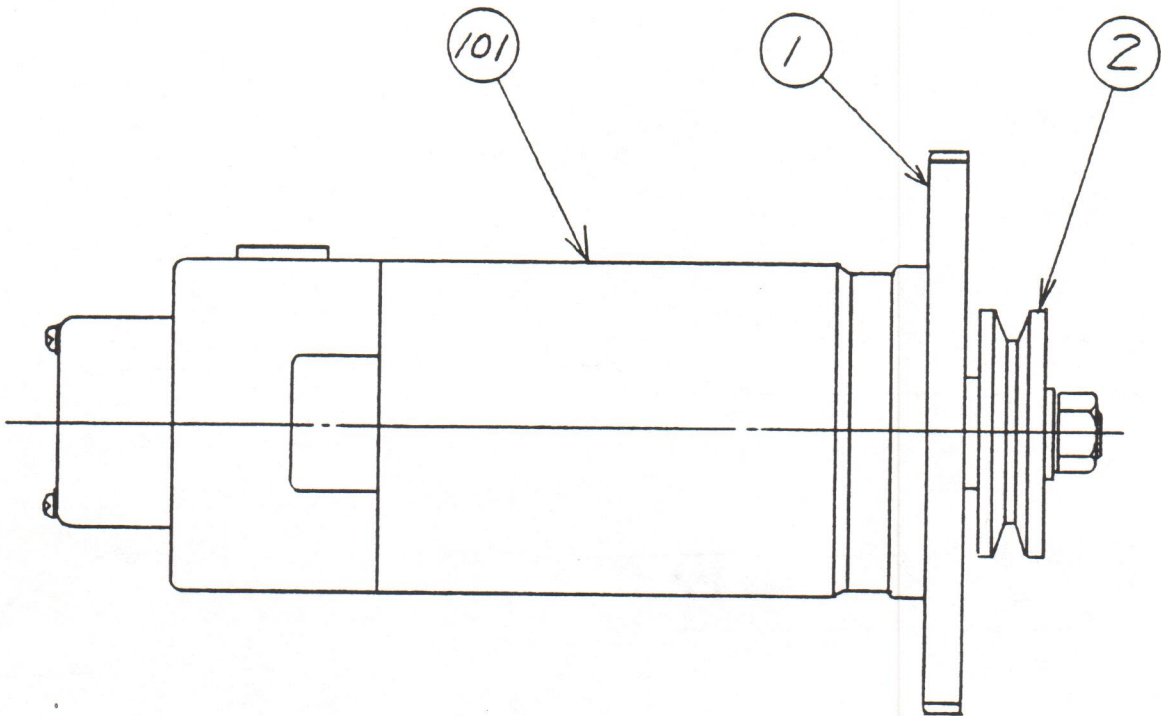

ITEM NO.	PART NO.	DESCRIPTION
1	YZ-3201	MOTOR BRKT
2	YZ-3202	DRIVE PULLEY
101	350-5134	MOTOR DC 80V W/ENCODER

①9 AC UNIT (YZ-3300)

(D-1/2)

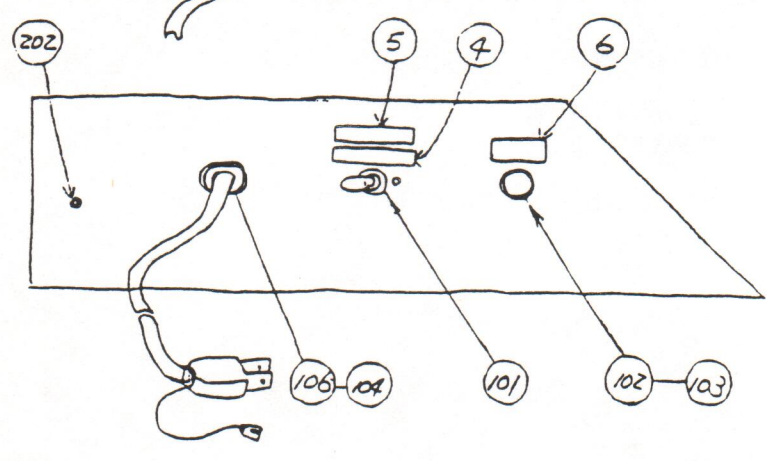
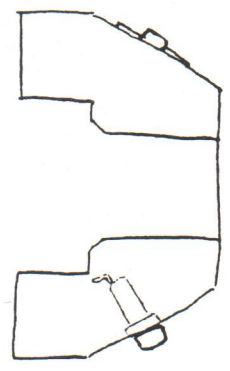
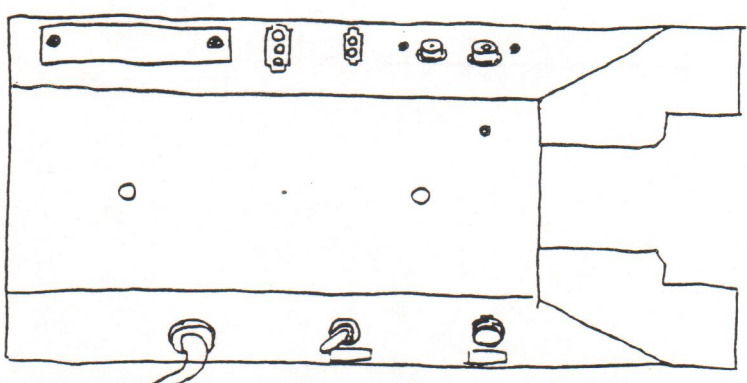
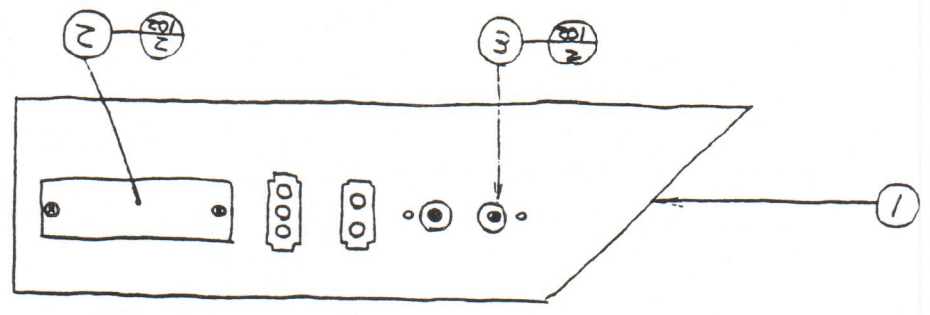

① AC UNIT (YZ-3300)

(D-2/2)

ITEM NO.	PART NO.	DESCRIPTION
1	YZ-3301	AC UNIT BASE
2	KR-2043	LID PLATE
3	210-5091	2P PHONO JACK
4	421-6592	STICKER ON-OFF
5	421-6950	STICKER MAIN SW
6	421-6595	STICKER
101	509-5234	SW TOGGLE 25A
102	514-5030	FUSE HOLDER
103	514-0037	FUSE 15A 6.4×30mm
104	600-0110	CABLE & PLUG ASSY W/EARTH (100~120V AREA)
	600-5007	CABLE & PLUG ASSY W/EARTH (200~240V AREA)
106	280-0418	BUSHING STRAIN RELIEF 8.4
201	010-0308-F	S TITE SCR PH W/F M3×8
202	000-0408-FS	M SCR PH W/FS M4×8



20 ASSY PWR SPLY MAIN (YZ-4000)

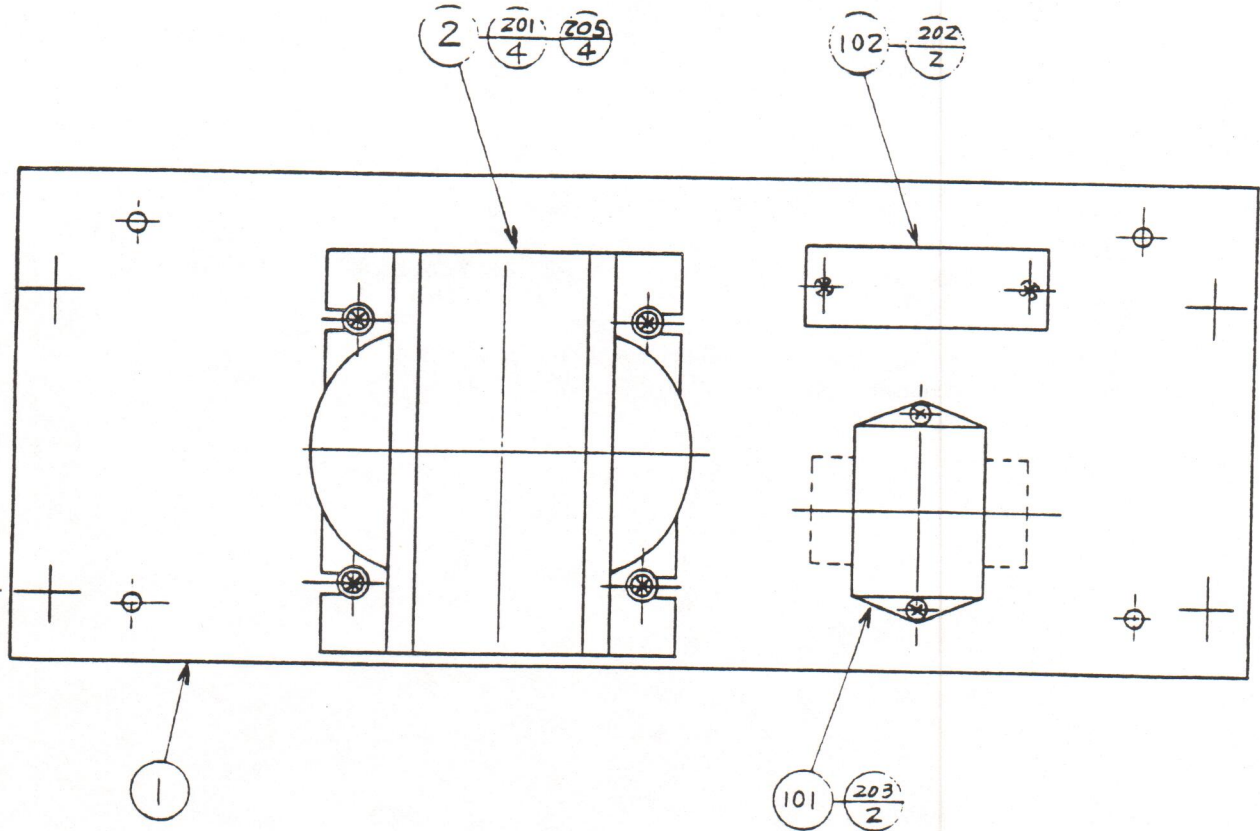

ITEM NO.	PART NO.	DESCRIPTION
1	YZ-4001	WOODEN BASE
2	560-5130	PWR XFMR 90-240V 18.5-18.5-100V
101	270-5022	NOISE FILTER 20A
102	117-5168	TERMINAL 6P 20A
201	000-0516-S	M SCR PH W/S M5×16
202	005-3516	W SCR RH 3.5×16
203	005-3513-F	W SCR RH W/F 3.5×13
204	006-3113	W SCR FH 3.1×13
205	069-0001	FLT WSHR 5.5×20×1.6

21 ASSY PWR SPLY SUB (YZ-4100)

(D-1/2)

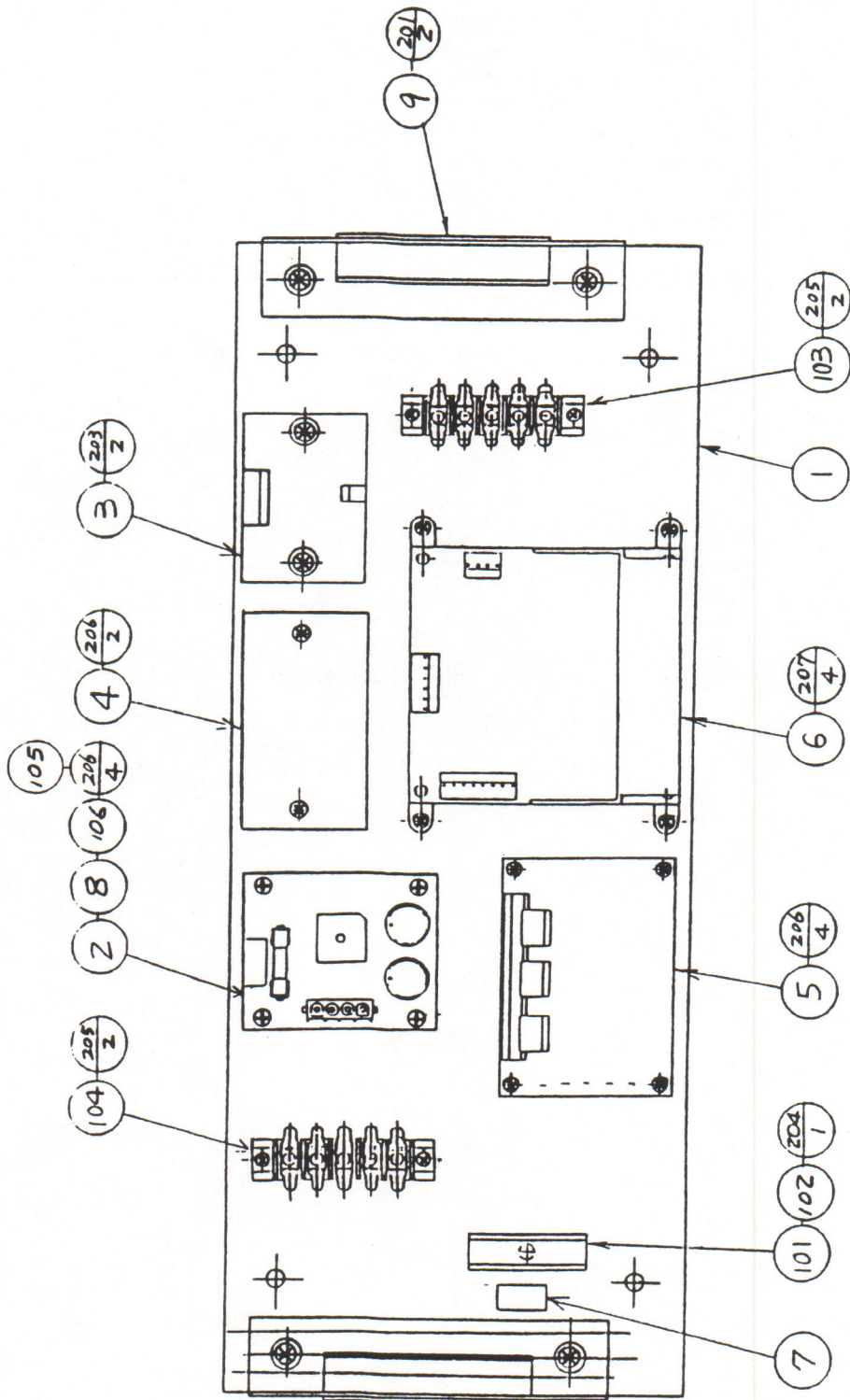

②1 ASSY PWR SPLY SUB (YZ-4100)

(D-2/2)

ITEM NO.	PART NO.	DESCRIPTION
1	YZ-4101	WOODEN BASE
2	839-0186	RECT BD DC 24V
3	839-0048	SSR BD DC MOTOR
4	839-0176	TR SUB BD
5	400-5070	DC/DC CONVERTER RV 5A
6	839-0035-01	PWR AMP DC 12V 10W
7	421-7207	STICKER FUSE INSTR
8	421-7208	STICKER FUSE INSTR
9	TX-4002	GRIP
101	514-5028	FUSE HOLDER 1P W/COVER
102	514-0034	FUSE 5A 6.4×30MM
103	117-5131	TERMINAL PLATE 5P
104	117-5167	TERMINAL 5P-2P×2 SHORT
105	601-6095	FUSE COVER
106	514-0043	FUSE 8A 6.4×30MM
107	280-0149	HARNESS LUG
108	280-5008	CORD CLAMP ∅ 15
201	000-0516-FS	M. SCR PH W/S.F M5×16
202	005-3513-F	W SCR RH W/F 3.5×13
203	005-3525	W SCR RH 3.5×25
204	005-3516	W SCR RH 3.5×16
205	005-3520	W SCR RH 3.5×20
206	029-0173	W SCR RH 2.7×25
207	006-3113	W SCR FH 3.1×13



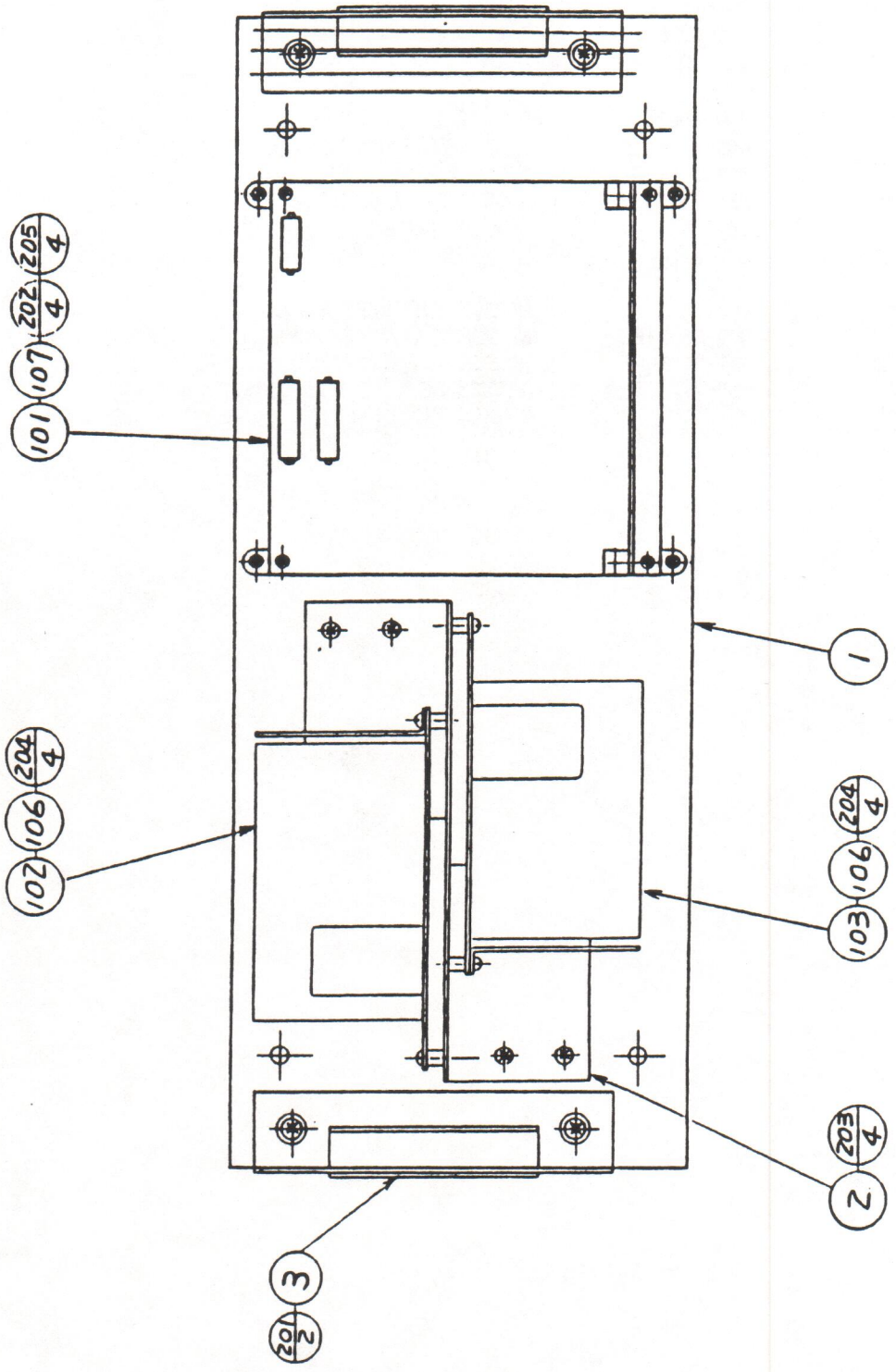

② ASSY PWR DRIVE (YZ-4200)

(D-2/2)

ITEM NO.	PART NO.	DESCRIPTION
1	YZ-4101	WOODEN BASE
2	YZ-4201	BRACKET
3	TX-4002	GRIP
101	400-5083	SW REG 90~240V
102	400-5084	FET PWR DRIVER (WHITE)
103	400-5084-01	FET PWR DRIVER (BROWN)
105	280-0419	HARNESS LUG
106	280-5045	SPACER TUBE 7
107	601-5214	L-LOCK
201	000-0516-FS	M SCR PH W/FS M5×16
202	000-0308-FS	M SCR PH W/FS M3×8
203	005-3513-F	W SCR RH W/F 3.5×13
204	010-0312-F	S-TITE SCR PH W/F M3×12
205	006-3113	W SCR FH 3.1×13

23 ASSY SW REGU & DRIVE BD (YZ-4300)

(D-1/2)

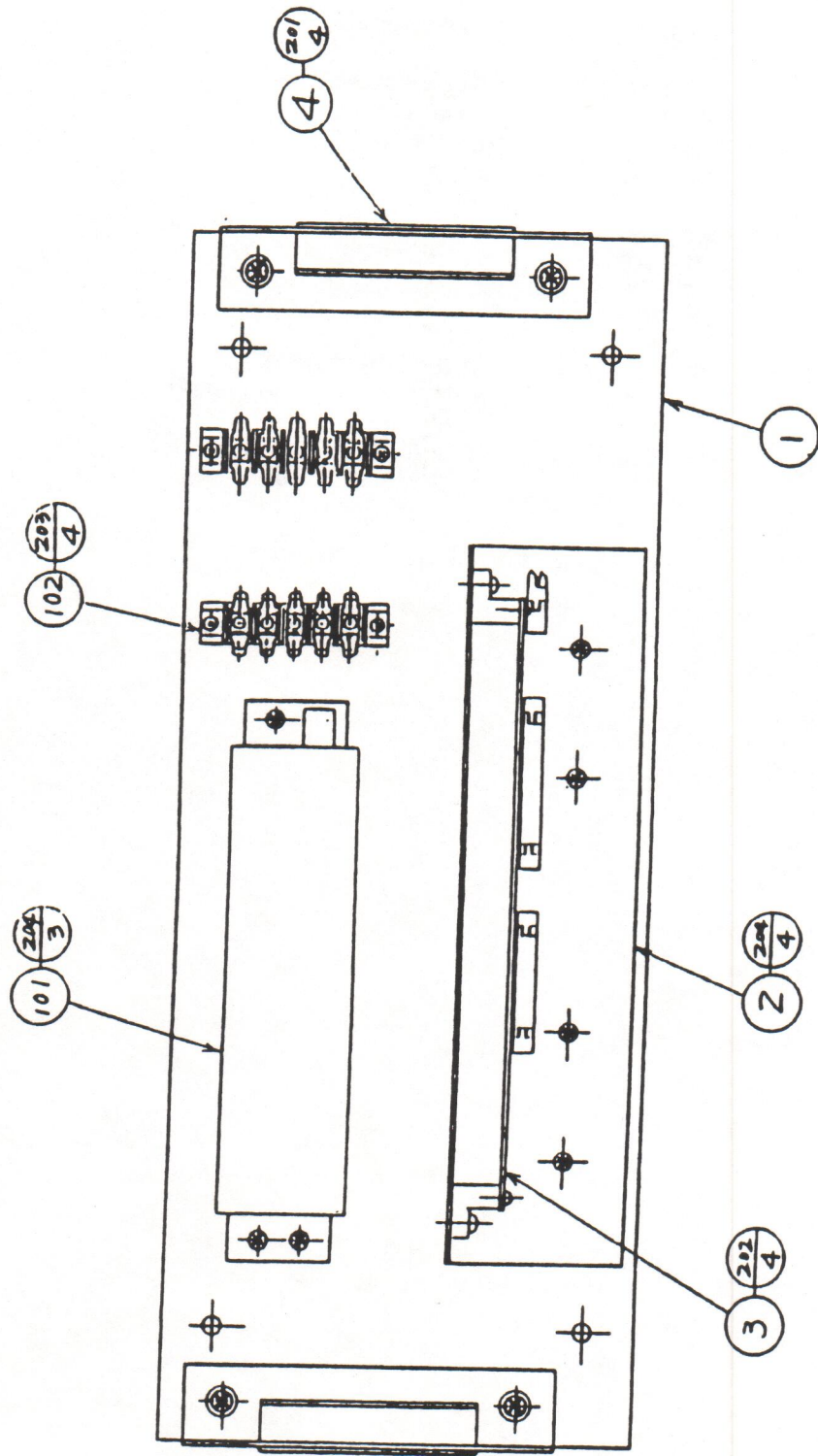



23

ASSY SW REGU & DRIVE BD (YZ-4300)

(D-2/2)

ITEM NO.	PART NO.	DESCRIPTION
1	YZ-4101	WOODEN BASE
2	YZ-4301	BRACKET
3	839-0161	DRIVE BD
4	TX-4002	GRIP
101	400-5055	SW REGU 90~240V 5V 10A
102	117-5166	TERM 5P-5P SHORT
103	280-5008	CORD CLAMP $\phi$ 15
104	280-0419	HARNES LUG
201	000-0516-FS	M SCR PH W/FS M5 $\times$ 16
202	010-0312-F	S-TITE SCR PH W/F M3 $\times$ 12
203	005-3250	W SCR RH 3.5 $\times$ 20
204	005-3513-F	W SCR RH W/F 3.5 $\times$ 13
205	006-3113	W SCR FH 3.1 $\times$ 13

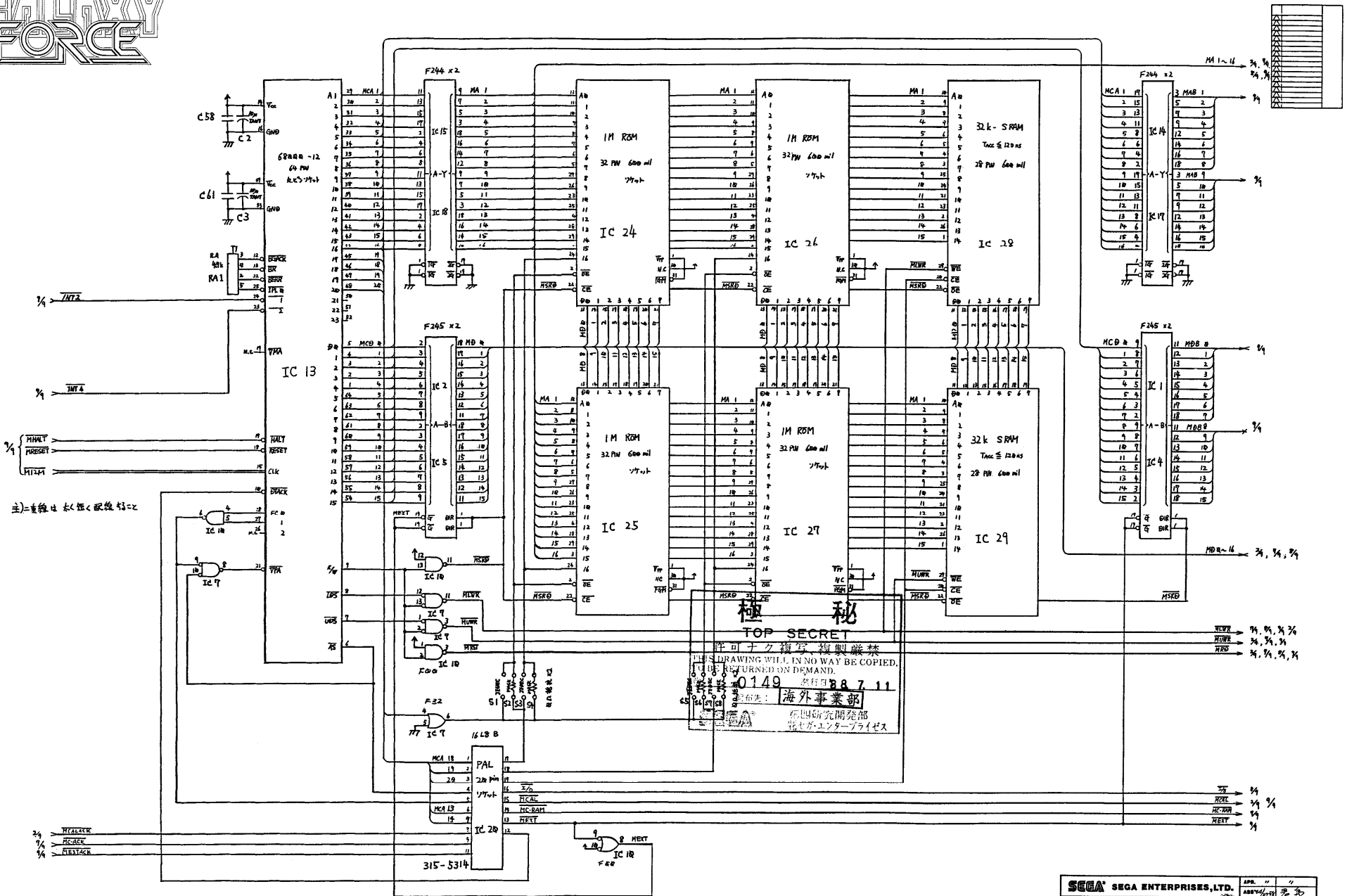

**極 秘**  
**TOP SECRET**  
 許可なく複写 複製厳禁  
 THIS DRAWING WILL IN NO WAY BE COPIED,  
 REPRODUCED OR TRANSMITTED IN ANY FORM  
 WITHOUT PERMISSION IN WRITING.  
 0149 発行日 88.7.11  
 海外事業部  
 研究開発部  
 エンタープライゼス

<b>SEGA SEGA ENTERPRISES, LTD.</b>		APP. NO. /
THIS DRAWING WILL IN NO WAY BE COPIED, REPRODUCED OR TRANSMITTED IN ANY FORM WITHOUT PERMISSION IN WRITING.		ASSY. NO. /
CPU BD		REV
GALAXY FORCE		B37-6565
DESCRIPTION		PART NO.
171-5609		SHEET 1 OF 9

(This line has been correctly scanned. It leads to nowhere)

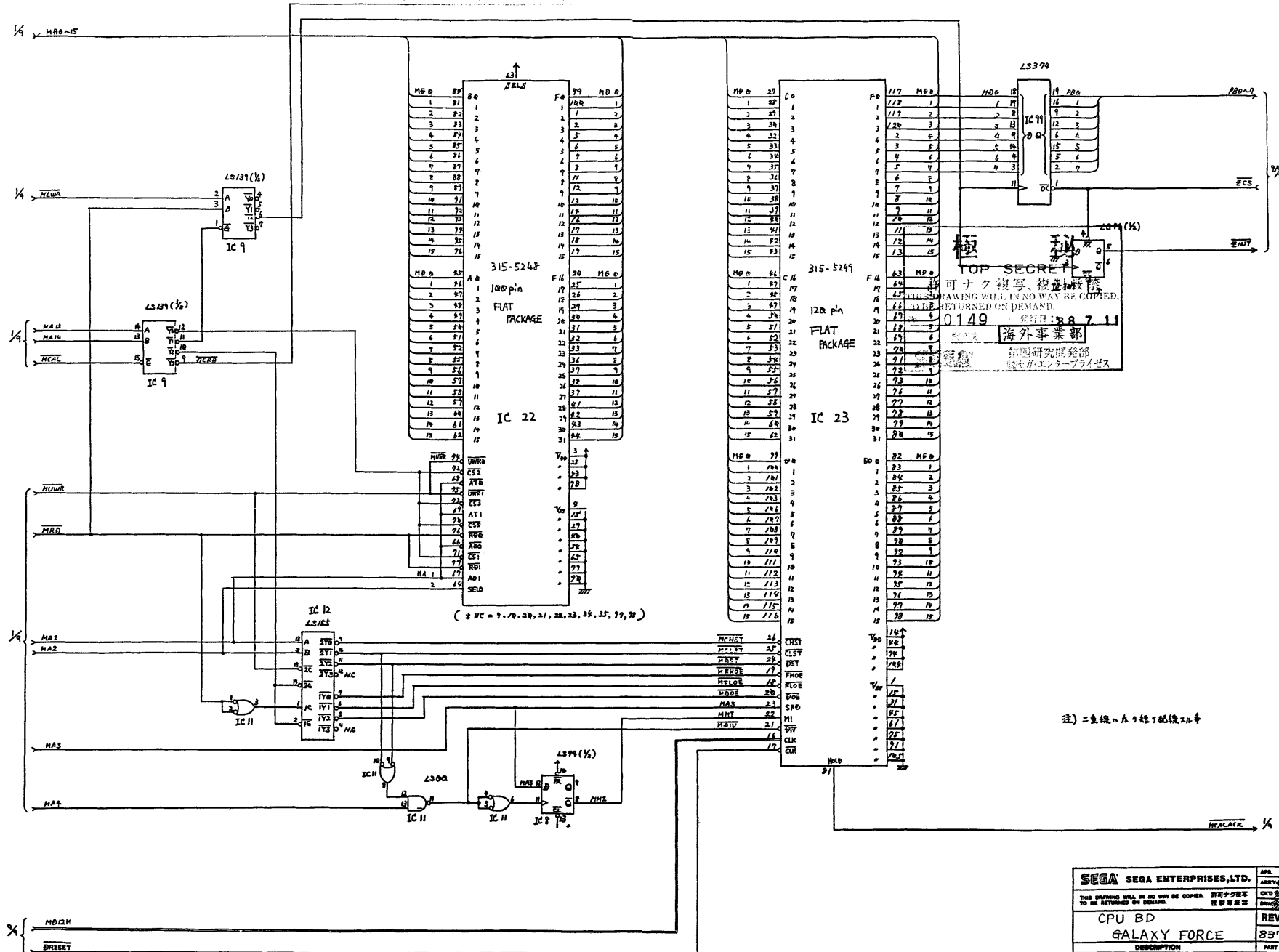

TOP SECRET  
 可ナク複写、複製、披露、  
 本圖は、本機に付属するもので、  
 本機を修理するに際しては、  
 必ずしも必要とするものではありません。  
 0149  
 発行日：88.7.11  
 海外事業部  
 本機研究開発部  
 富士通エンジニアリング

注) 二重線ハナリ線は配線順序

SEGA SEGA ENTERPRISES, LTD.	APL. 11/11
THIS DRAWING WILL BE NO WAY BE COPIED. 許可なく複製、 TO BE RETURNED ON DEMAND. 複製等禁止 本図を返却する	REV. 11/11
CPU BD	REV
GALAXY FORCE	887-6565
DESCRIPTION	PART NO.
171-5609	SHEET 2 OF 9



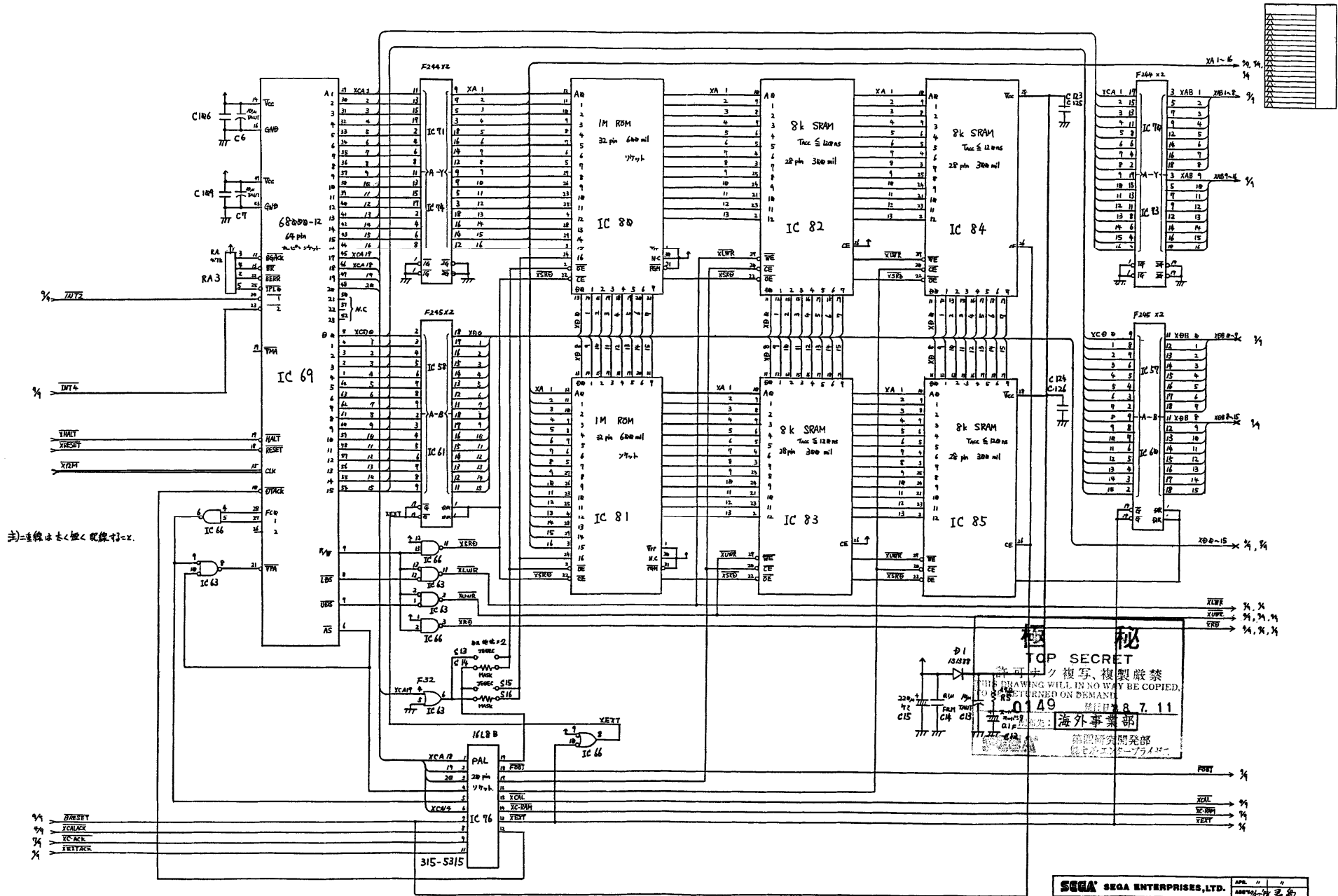

注) 2重線は太く短く 1重線は細く長く

**TOP SECRET**  
 許可なく複製、複製厳禁  
 THIS DRAWING WILL IN NO WAY BE COPIED,  
 REPRODUCED OR REFERRED ON DEMAND.  
 0149  
 1987.11  
 海外事業部  
 開発部

<b>SEGA SEGA ENTERPRISES, LTD.</b>		APL	11	0
THIS DRAWING WILL IN NO WAY BE COPIED, REPRODUCED OR REFERRED ON DEMAND. 許可なく複製、複製厳禁		REV	11	0
CPU BD		REV	11	0
GALAXY FORCE		REV	11	0
DESCRIPTION		PART	NO.	
171-5609		PART	NO.	
		SHEET	3	OF 9

Xf X00~15

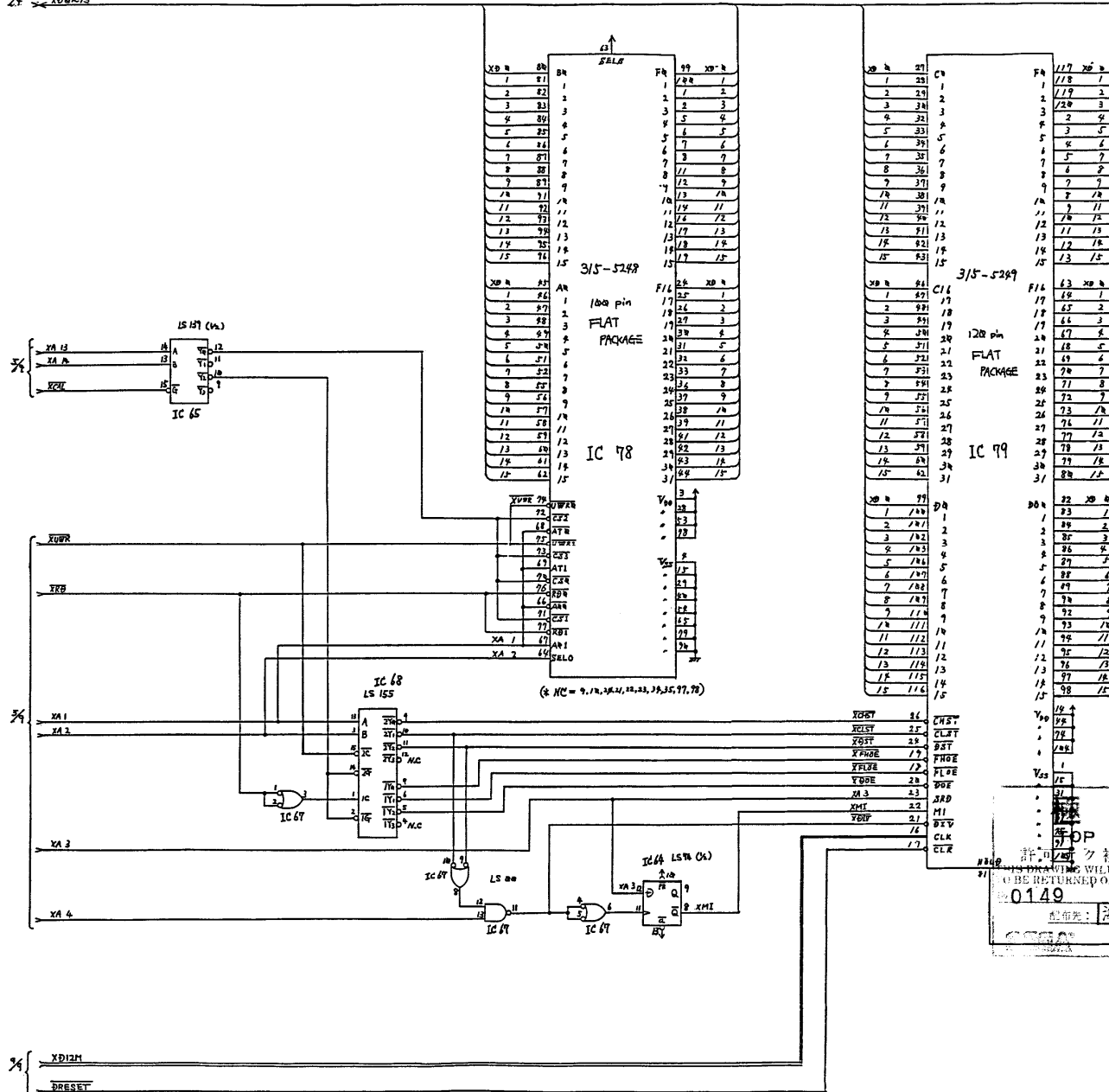

**秘**  
TOP SECRET

許可なく複製、複製厳禁  
THIS DRAWING WILL IN NO WAY BE COPIED.  
TO BE RETURNED ON DEMAND.

0149 発行日 3.8.7.11

配布先: 海外事業部  
第四研究開発部

YOUNG 34

(注) 二重線ハネは2重配線スルヲ

SEGA SEGA ENTERPRISES, LTD.	APP. 〃 〃
THE DRAWING WILL IN NO WAY BE COPIED. TO BE RETURNED ON DEMAND.	ASSY 〃 〃
CPU BD	REV
GALAXY FORCE	837-6565
DESCRIPTION	PART NO.
171-5609	SHEET 4 of 7

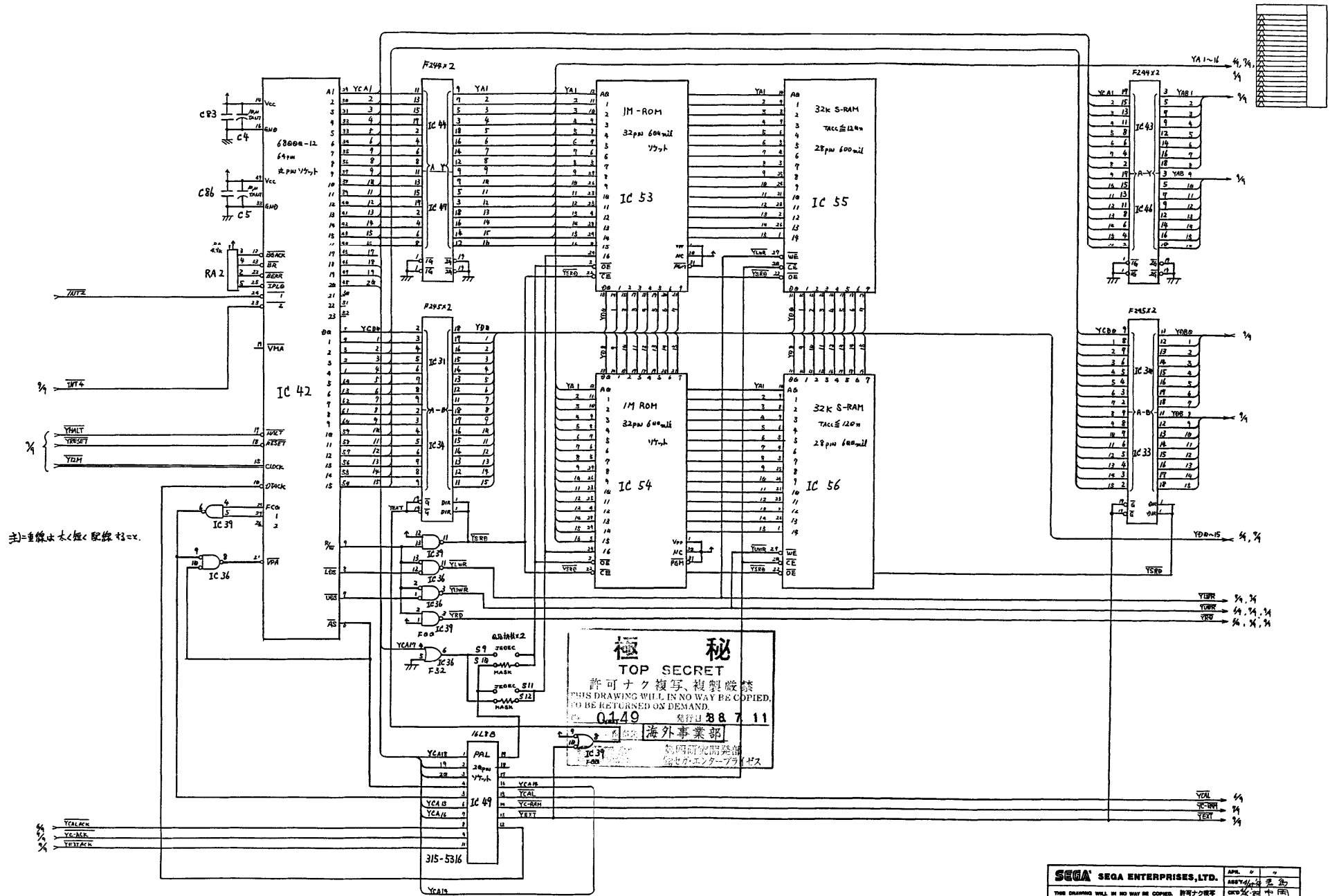

注) 直線は太く短く配線してください。

**極 秘**  
**TOP SECRET**  
 許可なく複写、複製、転載、  
 THIS DRAWING WILL IN NO WAY BE COPIED,  
 TO BE RETURNED ON DEMAND.  
 0.149 発行日 88.7.11  
 海外事業部  
 Sega Enterprises, Ltd.  
 1-000

<b>SEGA SEGA ENTERPRISES, LTD.</b>		APPL. 4 ASSY. 4 CRY. 4 DRW. 4
THIS DRAWING WILL IN NO WAY BE COPIED, TO BE RETURNED ON DEMAND.		許可なく複写、 複製、転載、 複製等禁止
<b>CPU BD</b> <b>GALAXY FORCE</b>		<b>REV</b> <b>837-6565</b>
DESCRIPTION		PART NO. SHEET 5 of 9
171-5609		



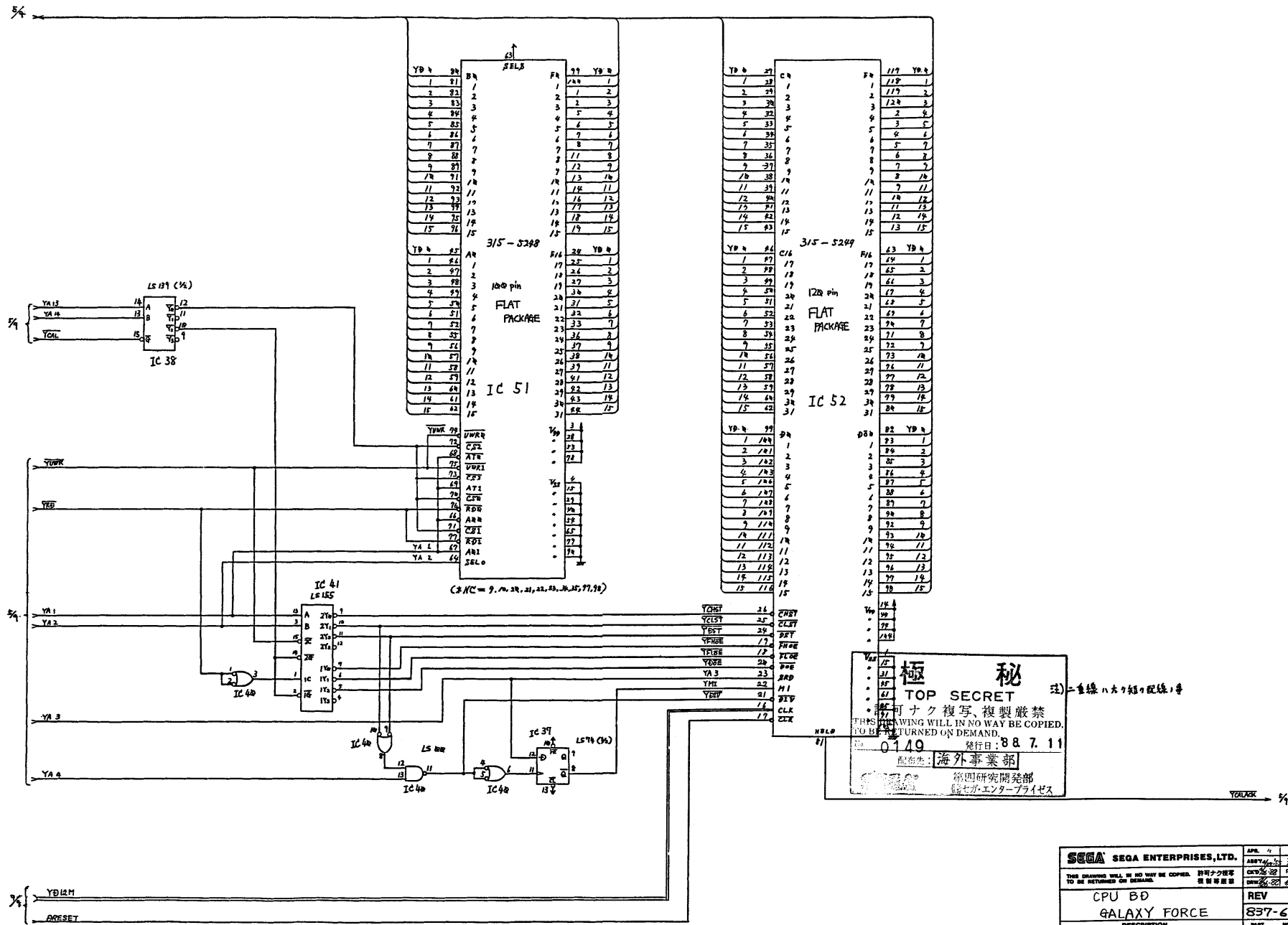

**極 秘**

TOP SECRET

可ナク複写、複製嚴禁  
THIS DRAWING WILL IN NO WAY BE COPIED,  
REPRODUCED OR TRANSMITTED IN ANY FORM  
WITHOUT THE WRITTEN PERMISSION OF SEGA ENTERPRISES, LTD.

發行日: 88.7.11

0149

配付先: 海外事業部

第四研究開発部  
セガエンタープライゼス

SEGA SEGA ENTERPRISES, LTD.		APR. 4 11
THIS DRAWING WILL IN NO WAY BE COPIED, REPRODUCED OR TRANSMITTED IN ANY FORM WITHOUT THE WRITTEN PERMISSION OF SEGA ENTERPRISES, LTD.		ASBY: 25 26
CPU BD		CHK: 28 中 既
GALAXY FORCE		DRW: 28 68 78
DESCRIPTION		REV
171-5609		HEET 2
		SHEET 6 of 9

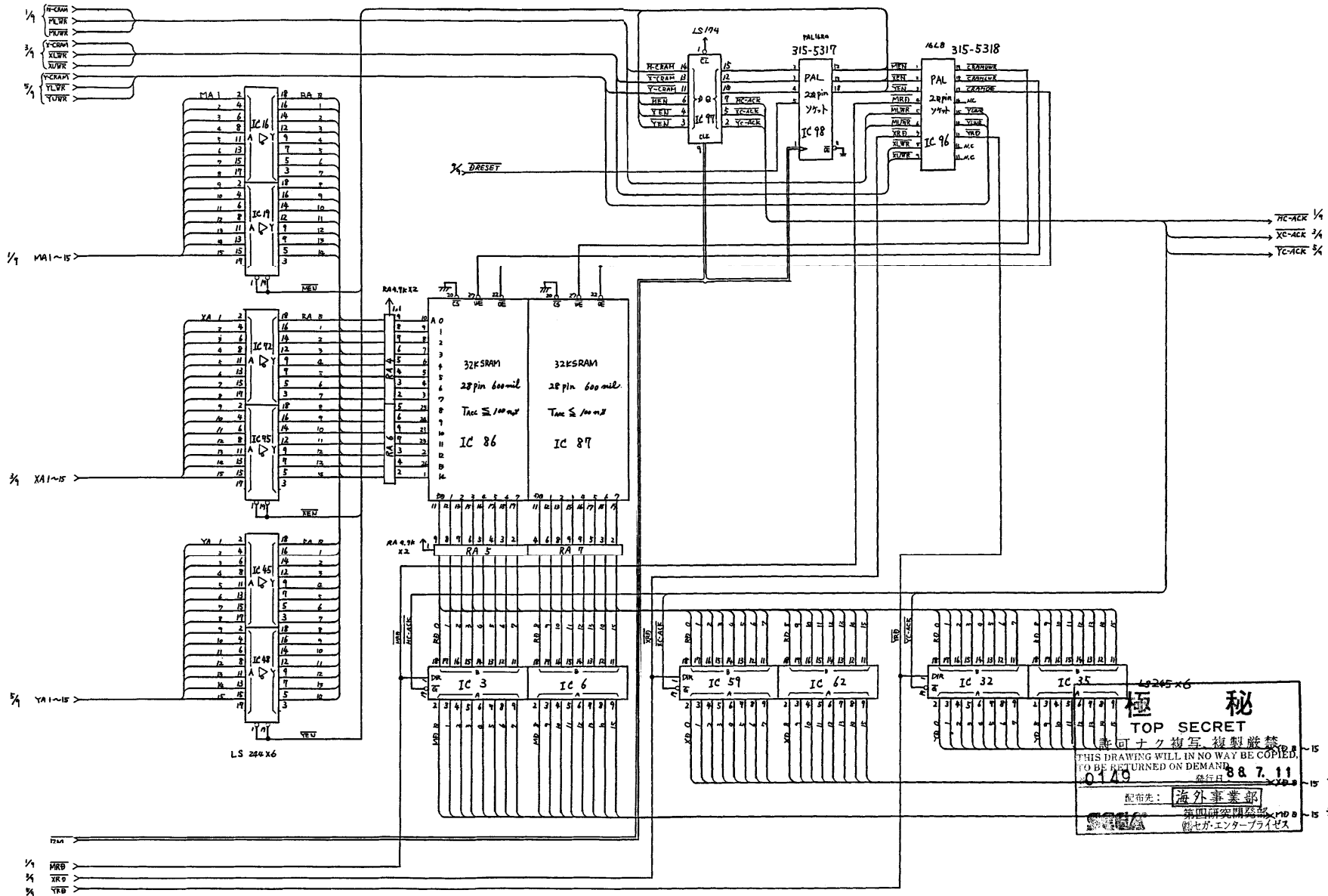

**極 秘**

TOP SECRET

許可なく複写・複製厳禁

THIS DRAWING WILL IN NO WAY BE COPIED,  
TO BE RETURNED ON DEMAND

0179 発行日 8 8 7. 11

配布先: 海外事業部

第四研究室 第二課

セガがエンタープライゼス

SEGA SEGA ENTERPRISES, LTD.		APL	11	11
THIS DRAWING WILL IN NO WAY BE COPIED, TO BE RETURNED ON DEMAND 許可なく複写・複製厳禁		ASBY	44	3
		CHK	58	2
		DRAW	28	1
CPU BD		REV		
GALAXY FORCE				
DESCRIPTION		PART	NO.	
		SHEET	7	OF 7
			171-5609	

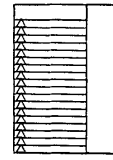
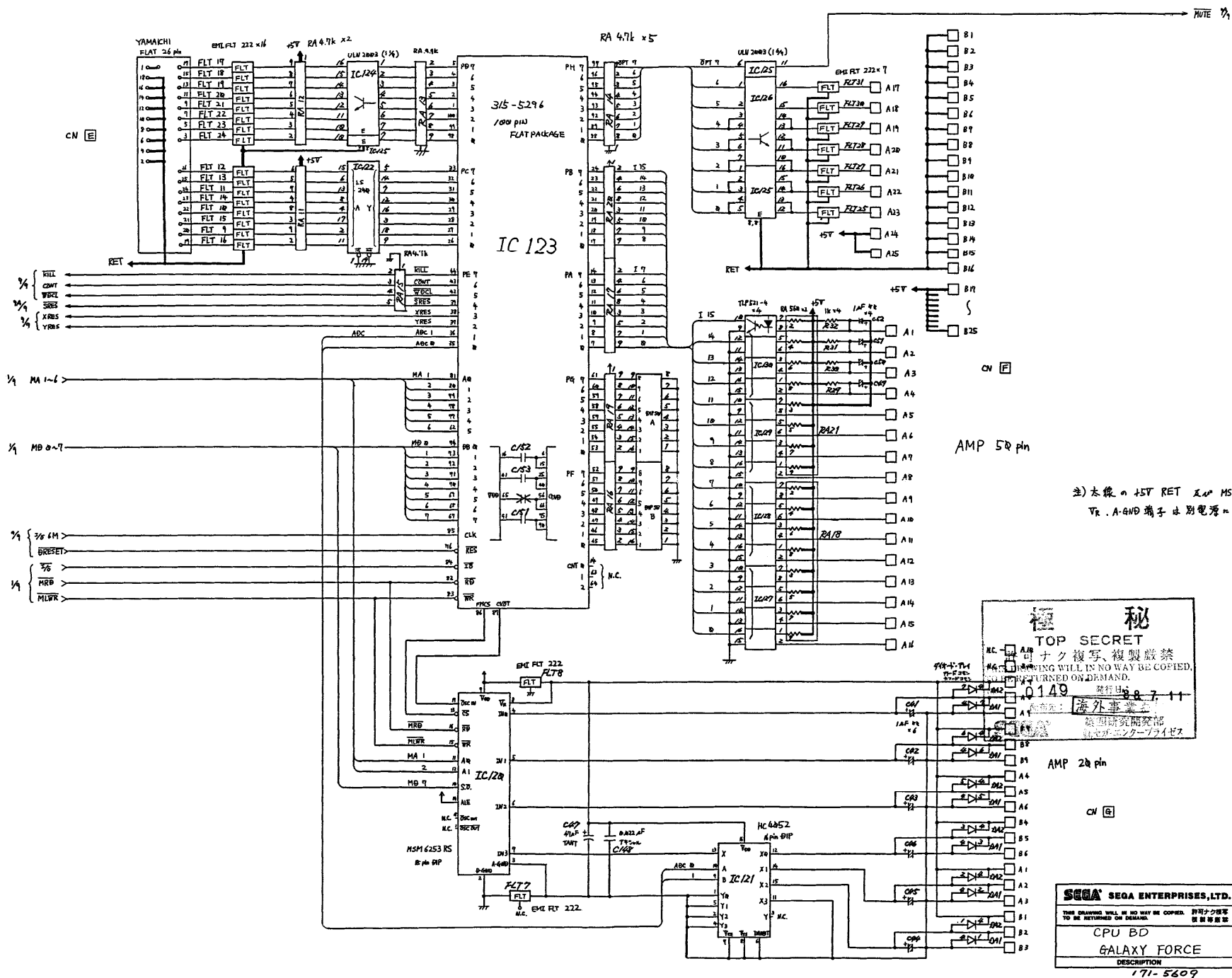

注) 本機の +5V RET 及び MSM6253 RS の  
Tr. A-GND 端子は別電源にて下す。

**秘**

TOP SECRET

この資料の複製・複製厳禁  
THIS DRAWING WILL IN NO WAY BE COPIED,  
REPRODUCED OR TRANSMITTED IN ANY FORM  
WITHOUT PERMISSION FROM THE ORIGINAL  
RETURNED ON DEMAND.

0149 発行日 80.7.11

海外事業部  
技術開発課  
システムエンジニアリング部

<b>SEGA SEGA ENTERPRISES, LTD.</b>		APR. 11	11
CPU BD		ASBY	島島
GALAXY FORCE		CHK	中野
DESCRIPTION		DWG	橋本
REV		REV	
837-6565		PART	NO.
171-5609		SHEET	8 OF 9



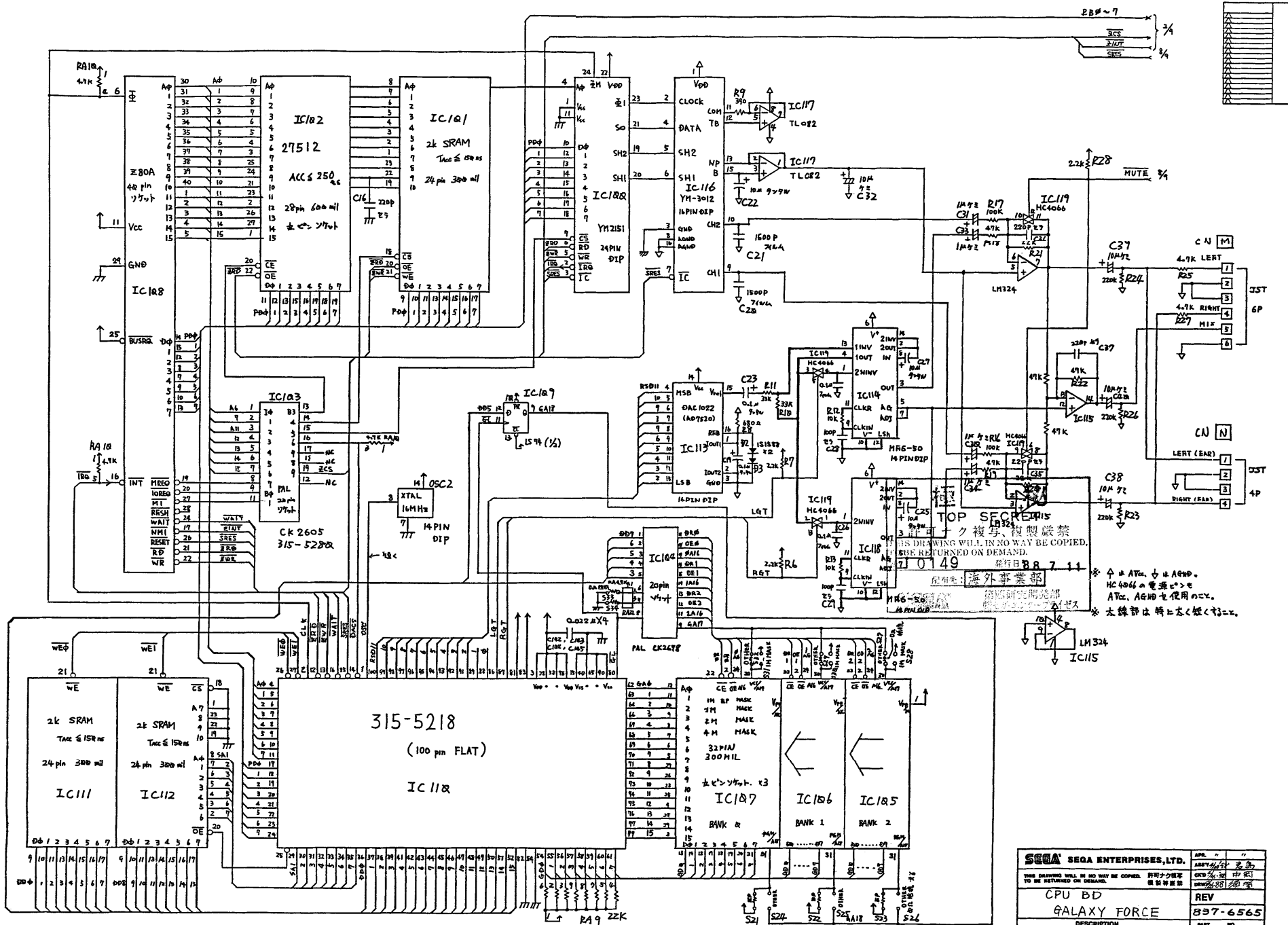

SEGA SEGA ENTERPRISES, LTD.		APL. " "
THIS DRAWING WILL BE NO WAY BE COPIED. 此明細書は複製を禁ずる。		AMB/44 克島
CPU BD		REV
GALAXY FORCE		B37-6565
DESCRIPTION		PART NO.
171-5609		SHEET 9A OF 9

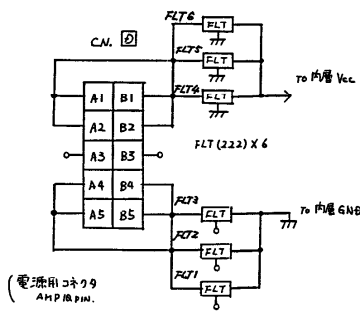
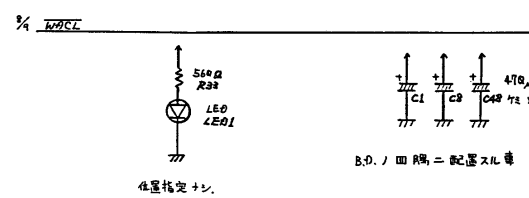
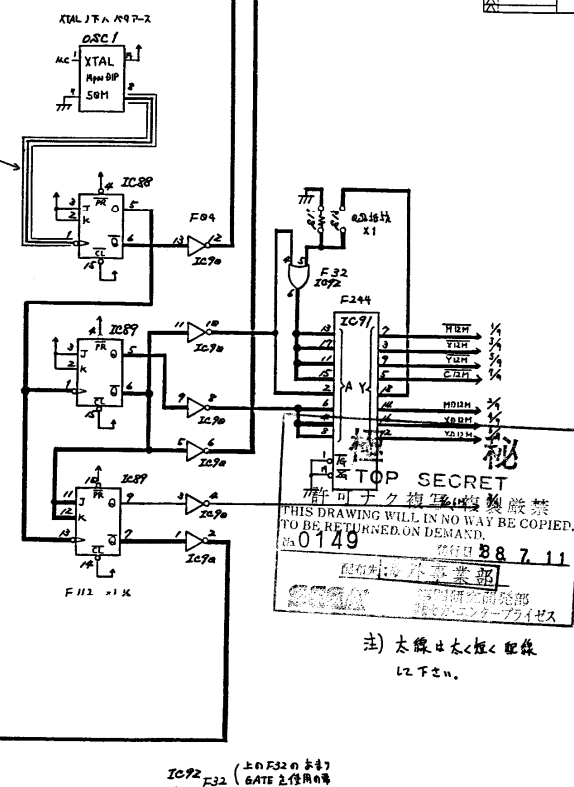
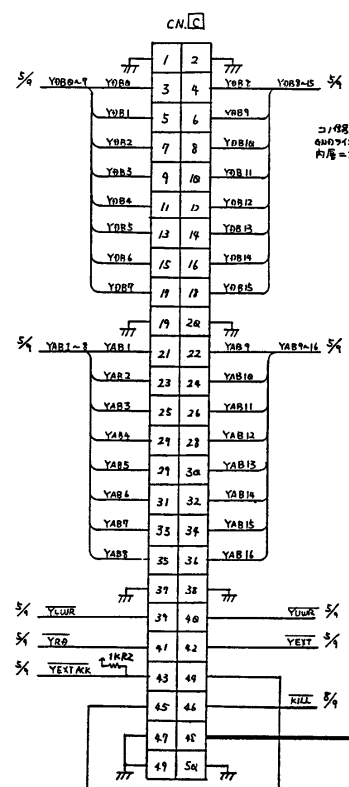
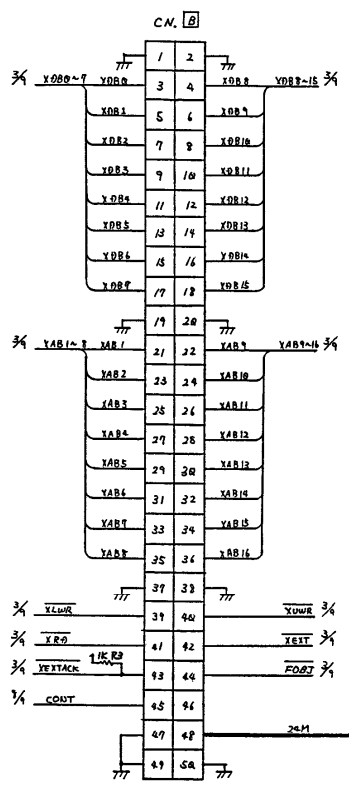
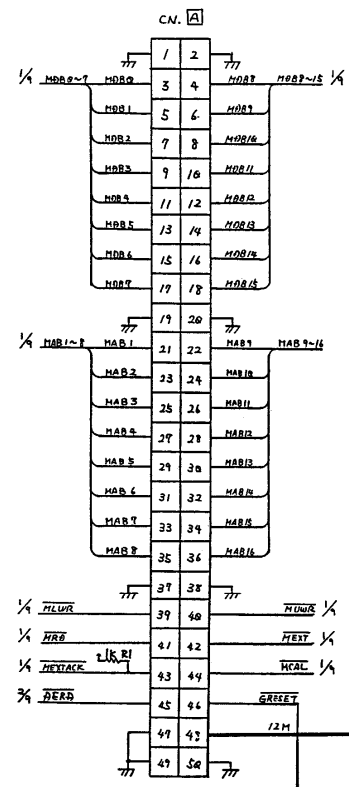
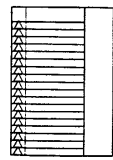

TOP SECRET  
 許可なく複製等の厳禁  
 THIS DRAWING WILL IN NO WAY BE COPIED,  
 TO BE RETURNED ON DEMAND.  
 0149  
 88.7.11  
 総務部  
 注) 本線日本へ転送配線  
 L2下参照

**SEGA SEGA ENTERPRISES, LTD.**  
 THIS DRAWING WILL IN NO WAY BE COPIED. 許可なく複製等の厳禁  
**CPU BD**  
**GALAXY FORCE**  
**DESCRIPTION**  
 171-5609

APR. 11 1988	REV
837-6565	PART NO.
171-5609	SHET 9 OF 9

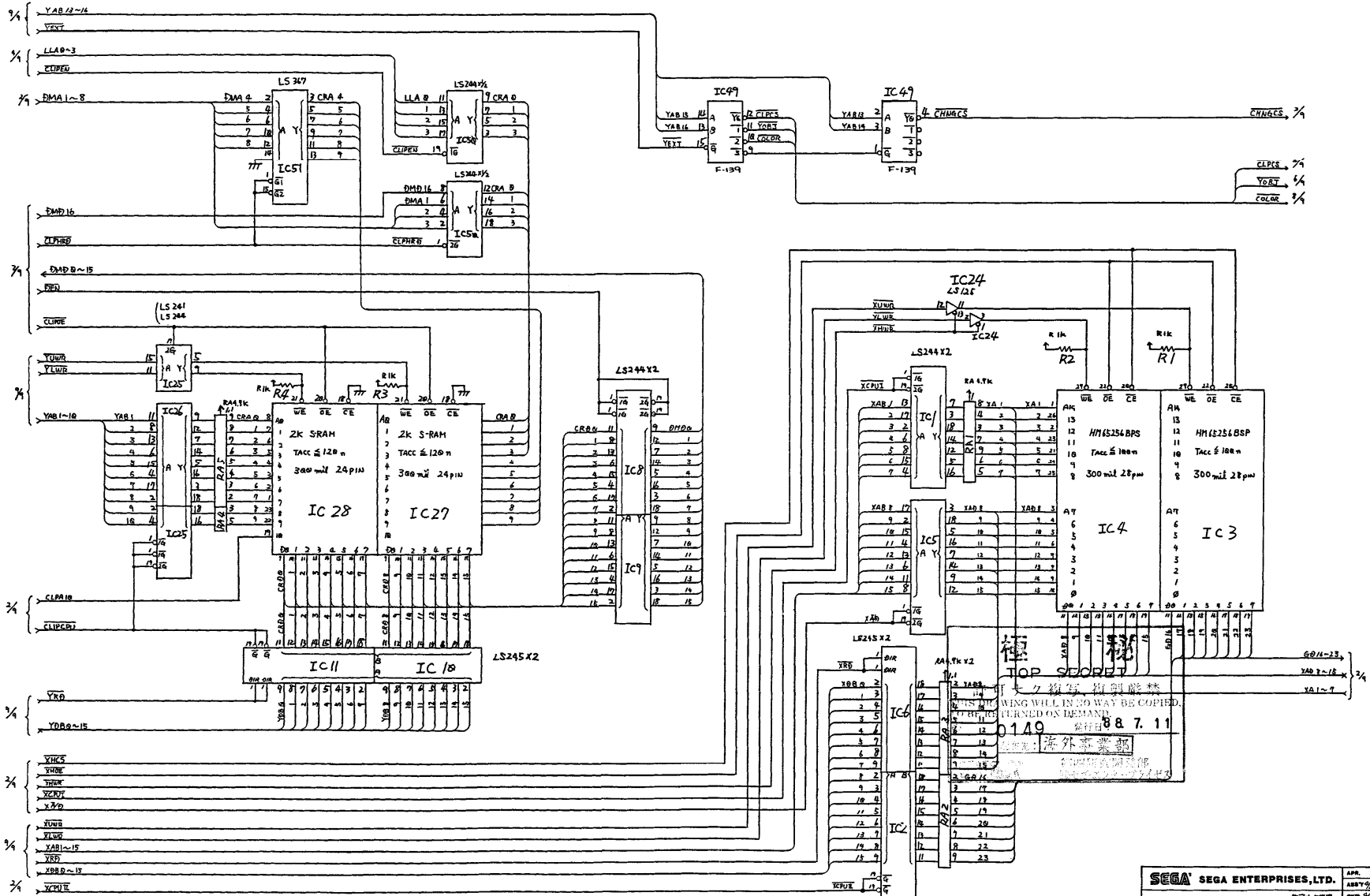
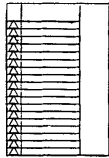

<b>SEGA</b> SEGA ENTERPRISES, LTD.		APP. 11 11
THIS DRAWING WILL IN NO WAY BE COPIED. 許可なく複写 複製等は厳禁 TO BE RETURNED ON DEMAND. 許可なく複写 複製等は厳禁		ABS'Y% 特電 高
VIDEO BD		OKD 中 印
GALAXY FORCE		REV 88.7.11
DESCRIPTION		837-6566
		PART NO.
		SHEET 1 OF X

TOP SECRET  
この資料は、特許権、著作権、商標権、その他の権利を侵害する可能性があります。複製、転載、または他の目的での使用を禁じます。 0140  
88.7.11  
海外営業部



\* 二重線は本基板の配線図に準拠

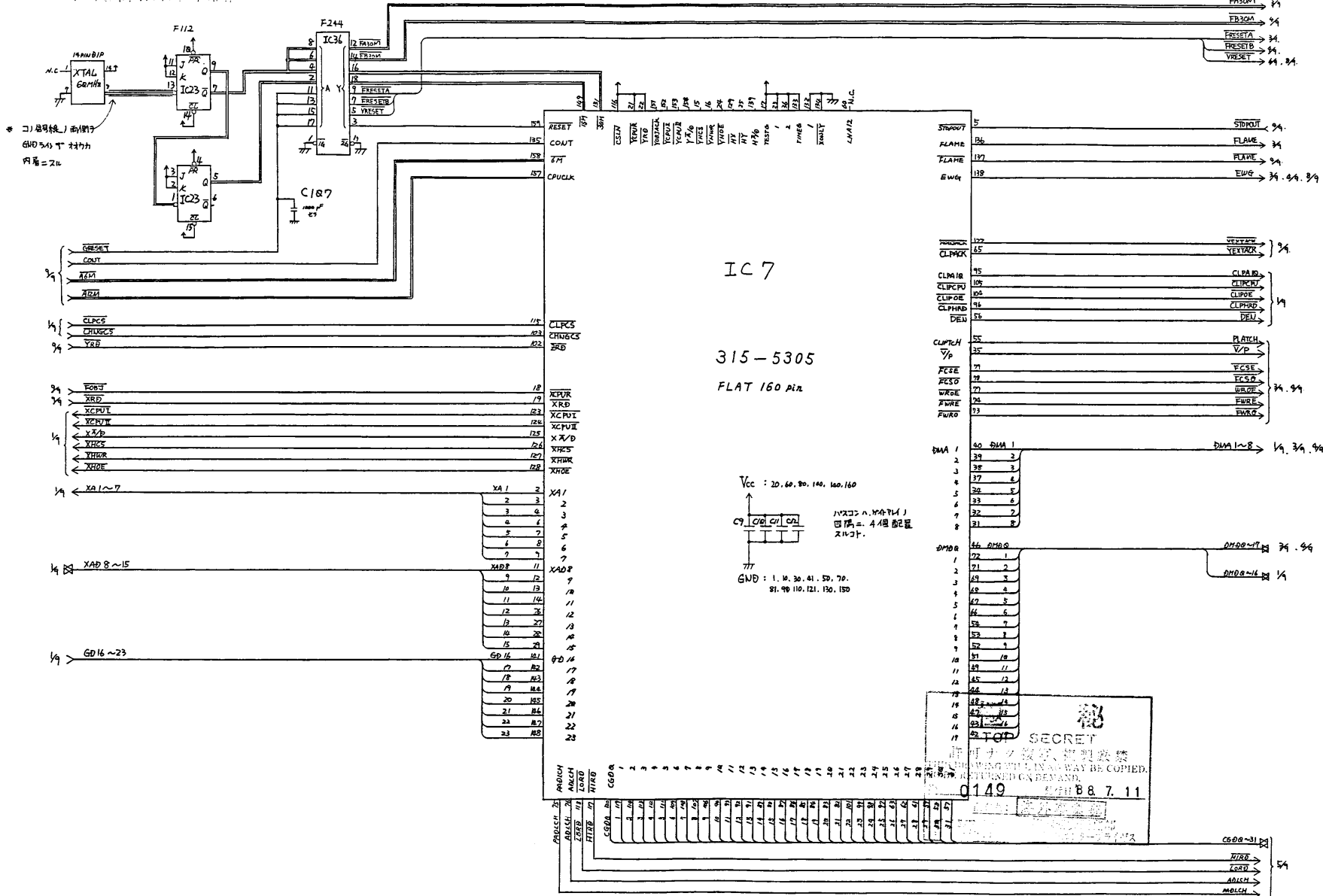

IC 7

315-5305  
FLAT 160 pin

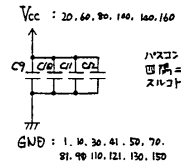

SECRET  
この図は複製禁止  
THIS DRAWING WILL IN NO WAY BE COPIED,  
REPRODUCED OR TRANSMITTED IN ANY FORM  
WITHOUT THE WRITTEN PERMISSION OF SEGA  
RETURNED ON DEMAND.  
0149  
REV B B 7. 11

SEGA SEGA ENTERPRISES, LTD.		APL	11	11
THIS DRAWING WILL IN NO WAY BE COPIED, TO BE RETURNED ON DEMAND. 許可なく複製 複製等禁止		CHK	11	11
VIDEO BD		REV		
GALAXY FORCE		837-6566		
DESCRIPTION		PART NO.		
171-5610		SHEET	2	OF X

1
2
3
4
5
6
7
8
9
10
11
12
13
14
15
16
17
18
19
20
21
22
23
24
25
26
27
28
29
30
31
32
33
34
35
36
37
38
39
40
41
42
43
44
45
46
47
48
49
50
51
52
53
54
55
56
57
58
59
60
61
62
63
64
65
66
67
68
69
70
71
72
73
74
75
76
77
78
79
80
81
82
83
84
85
86
87
88
89
90
91
92
93
94
95
96
97
98
99
100

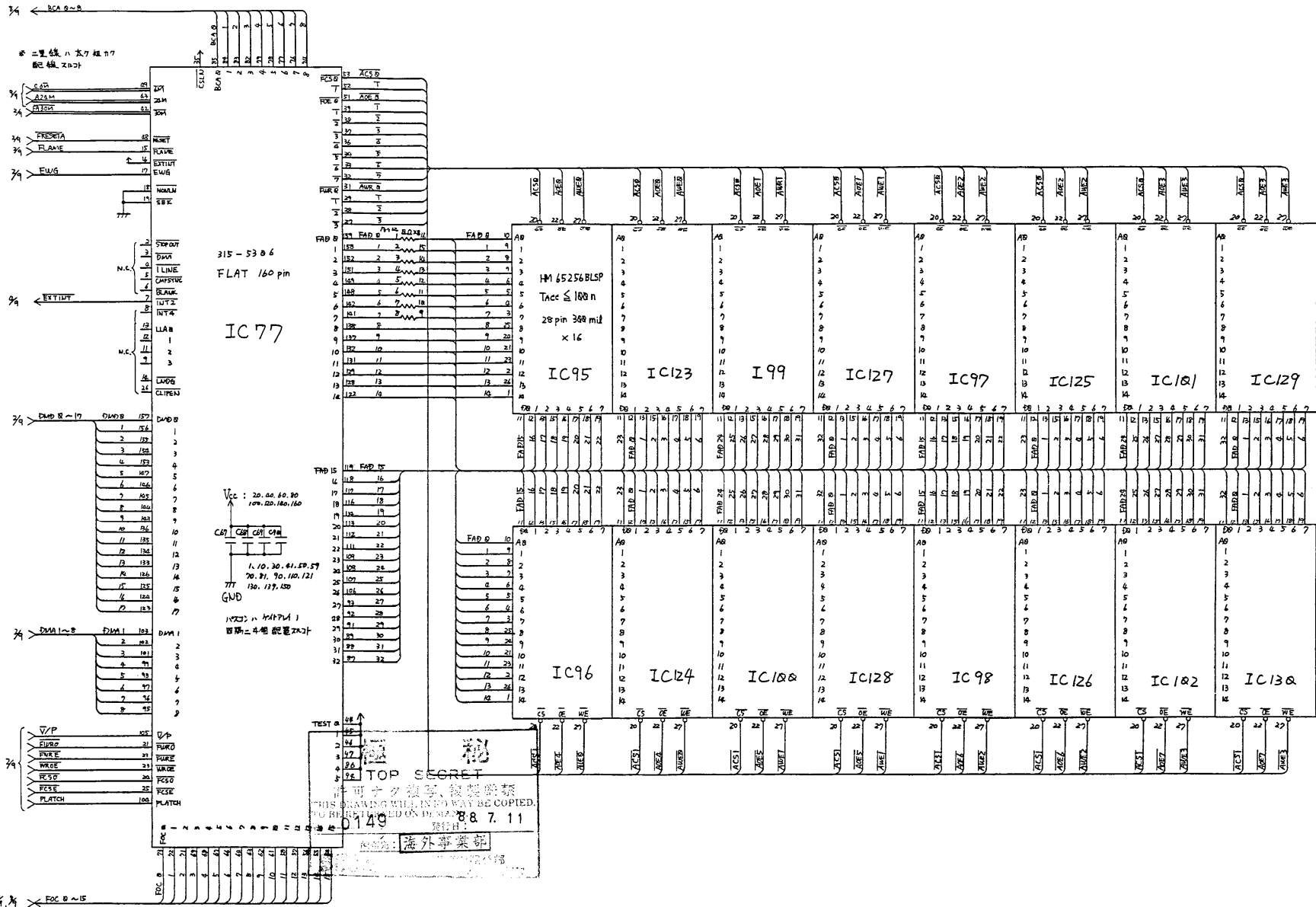

**SEGA SEGA ENTERPRISES, LTD.**  
 APR. 11 11  
 ABSY 4/11 11  
 CND 2/28 11  
 DWV 2/28 11  
 THIS DRAWING WILL IN NO WAY BE COPIED, REPRODUCED OR TRANSMITTED IN ANY FORM OR BY ANY MEANS, WITHOUT PERMISSION IN WRITING FROM SEGA ENTERPRISES, LTD.  
 VIDEO BD  
 GALAXY FORCE  
 DESCRIPTION  
 171-5610  
 REV  
 837-6566  
 PART NO.  
 SHEET 3 OF X

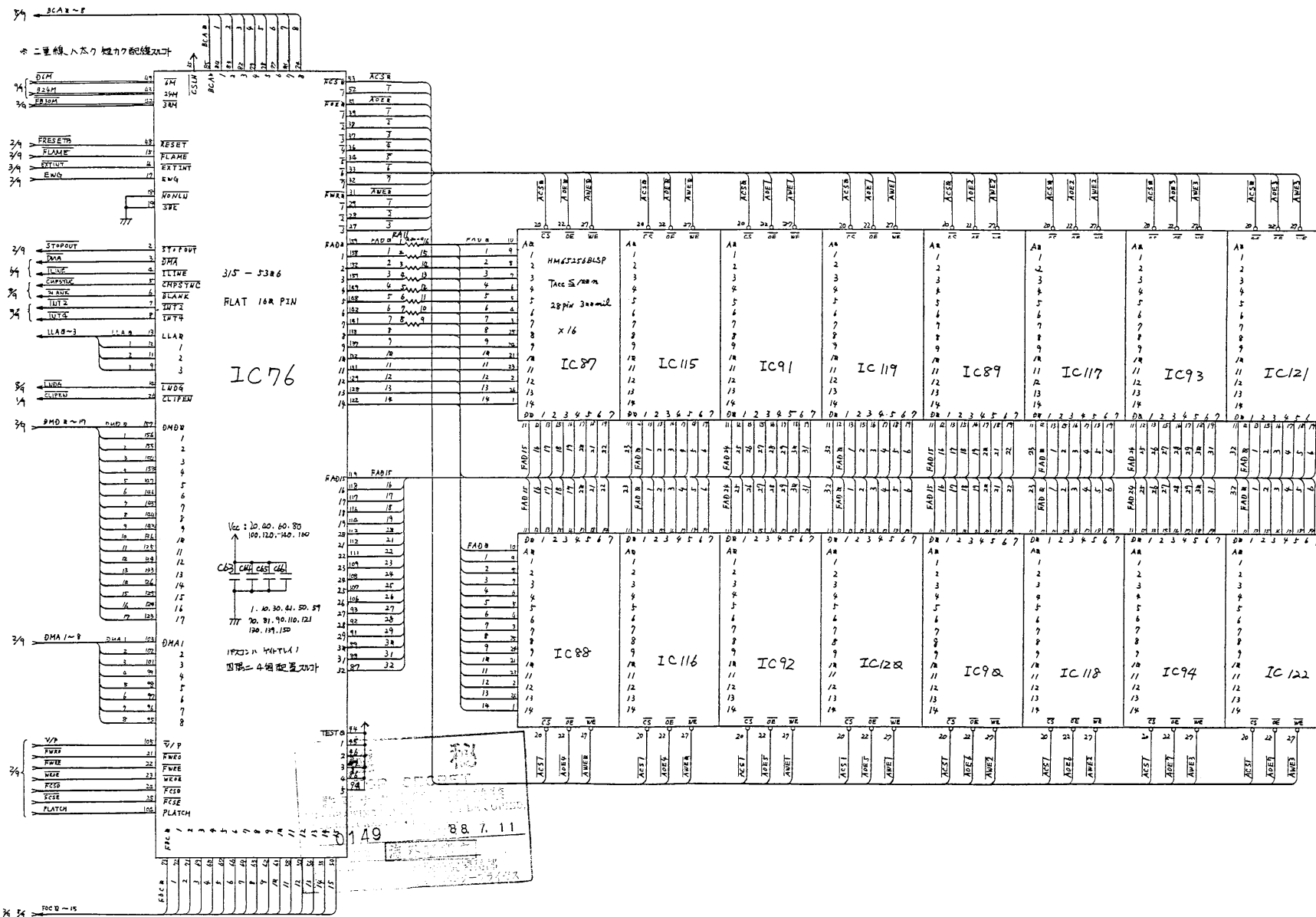

SEGA SEGA ENTERPRISES, LTD.	APL. " " " "
THIS DRAWING WILL IN NO WAY BE COPIED. 許可なく複製 TO BE RETURNED ON DEMAND. 複製無断返却	Assy 仕様表 部品表 部品別表 部品別表
VIDEO BD	REV
GALAXY FORCE	837-6566
DESCRIPTION	PART NO.
171-5610	SHEET 4 OF X



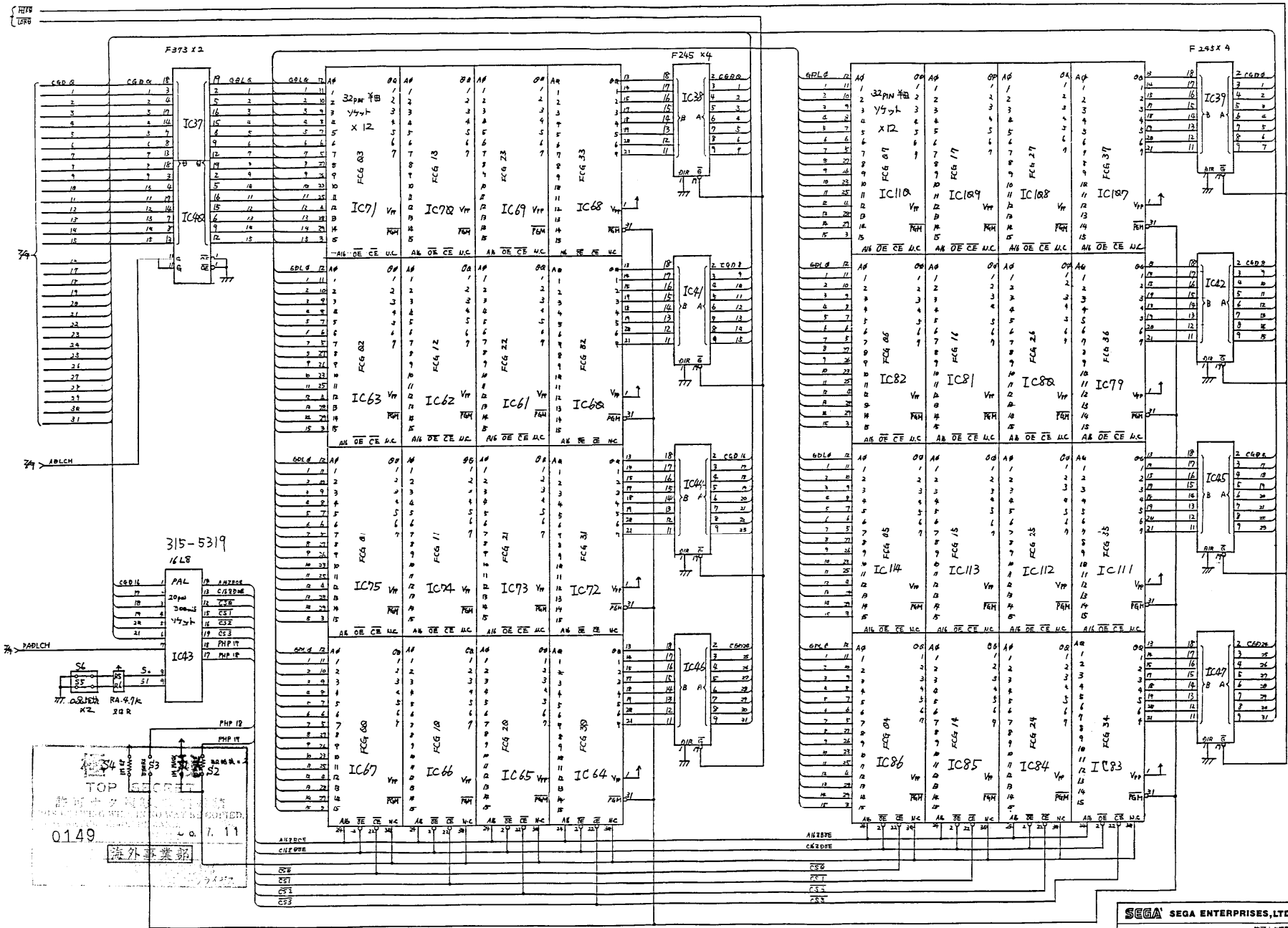

SEGA SEGA ENTERPRISES, LTD. APR. 11 1985  
 THIS DRAWING WILL IN NO WAY BE COPIED. 許可なく複製 許可なく複製  
 TO BE RETURNED ON DEMAND. 複製等禁止 複製等禁止

VIDEO BD  
 GALAXY FORCE  
 DESCRIPTION

REV  
 837-6566  
 PART NO.  
 SHEET 5 OF X

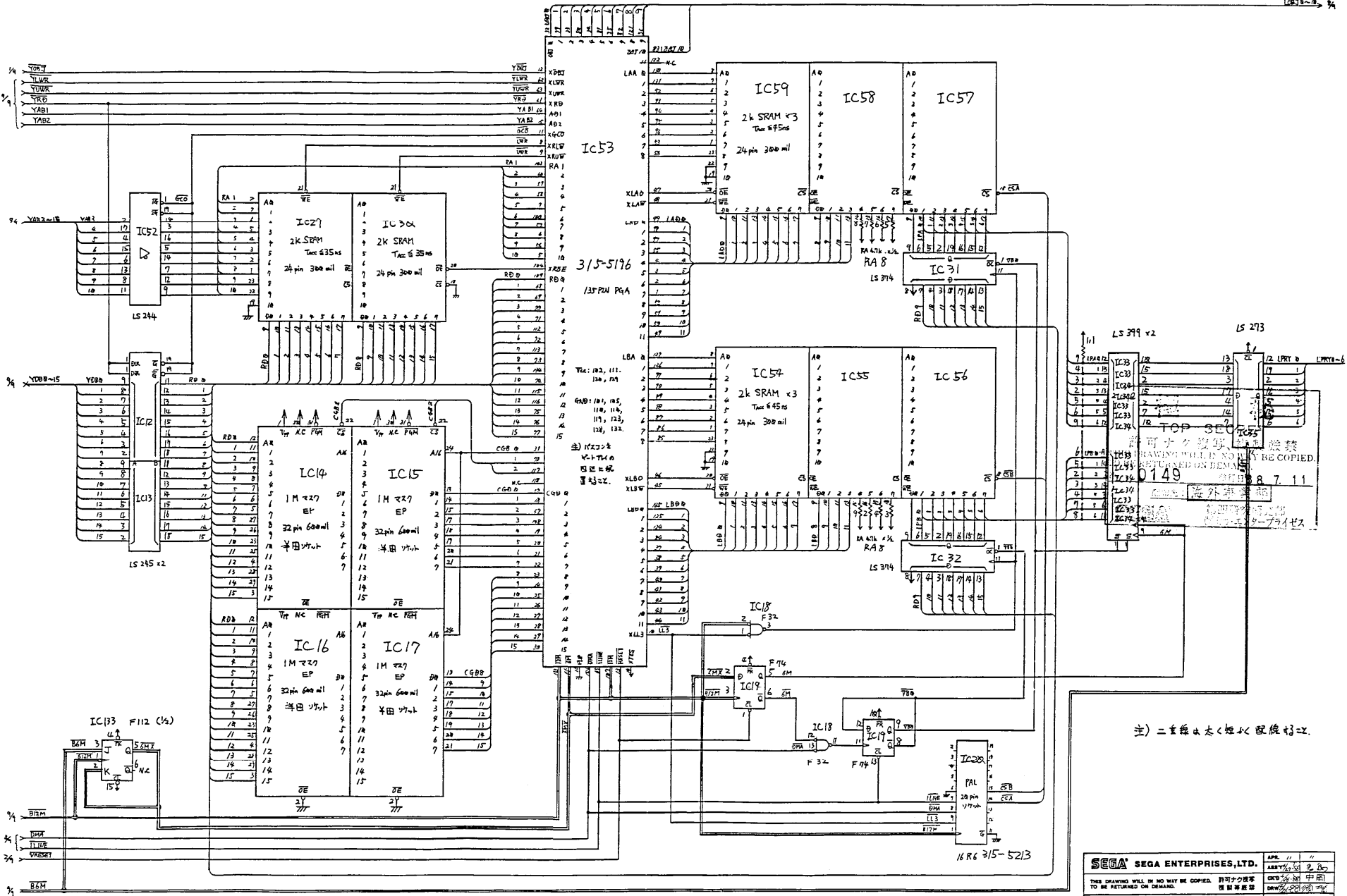

IC59  
2k SRAM x3  
Tacc 545ns  
24 pin 300 mil

IC58  
2k SRAM x3  
Tacc 545ns  
24 pin 300 mil

IC57  
2k SRAM x3  
Tacc 545ns  
24 pin 300 mil

IC54  
2k SRAM x3  
Tacc 545ns  
24 pin 300 mil

IC55  
2k SRAM x3  
Tacc 545ns  
24 pin 300 mil

IC56  
2k SRAM x3  
Tacc 545ns  
24 pin 300 mil

IC14  
1M 2x7  
EP  
32 pin 600 mil  
半田付

IC15  
1M 2x7  
EP  
32 pin 600 mil  
半田付

IC16  
1M 2x7  
EP  
32 pin 600 mil  
半田付

IC17  
1M 2x7  
EP  
32 pin 600 mil  
半田付

IC13 F112 (1/2)

LS244

LS245 x2

LS273

LS399 x2

LS374

LS374

LS374

LS374

TOP SECRET  
COPYING OR REPRODUCING THIS DRAWING WILL IN NO WAY BE COPIED.  
RETURNED ON DEMAND.  
0149  
8.7.11

注) 二重線は本寸短く配線対応。

16R6 315-5213

SEGA SEGA ENTERPRISES, LTD.	APL	///
THIS DRAWING WILL IN NO WAY BE COPIED. 許可なく複製等 TO BE RETURNED ON DEMAND. 複製等無断 返却等無断	ASSY	///
VIDEO BD	CHK	///
GALAXY FORCE	REV	///
DESCRIPTION	837-6566	///
	PART	NO.
	SHEET	6 OF 8

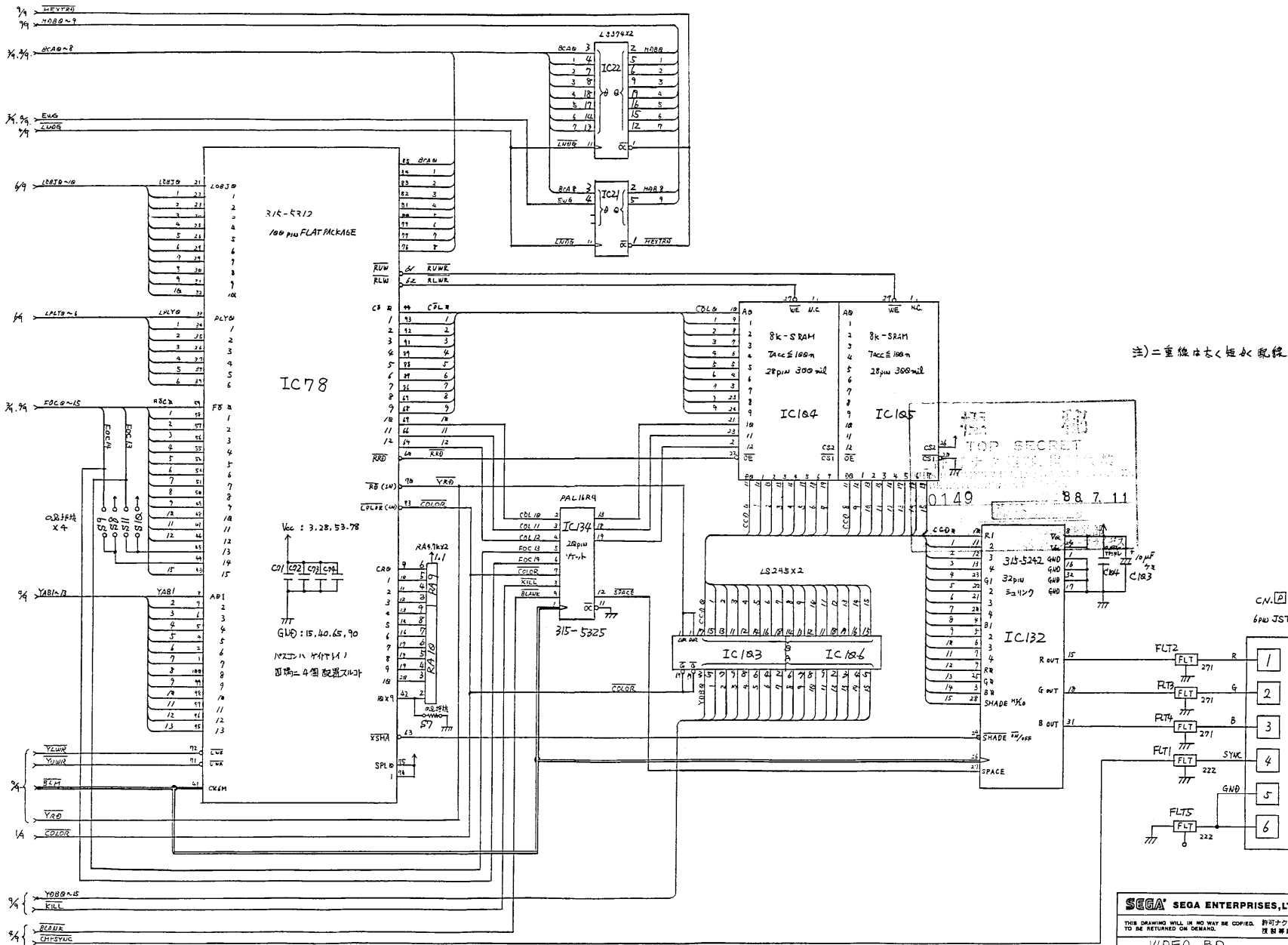

注) = 重複は太く短く配線してください。

<b>SEGA SEGA ENTERPRISES, LTD.</b>		APR. 11 1987
THIS DRAWING WILL IN NO WAY BE COPIED, REPRODUCED OR TRANSMITTED IN ANY FORM OR BY ANY MEANS, WITHOUT THE WRITTEN PERMISSION OF SEGA ENTERPRISES, LTD.		REV
VIDEO BD GALAXY FORCE		837-6566
DESCRIPTION		PART NO.
171-5610		SHEET 7 OF X



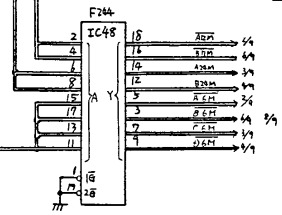
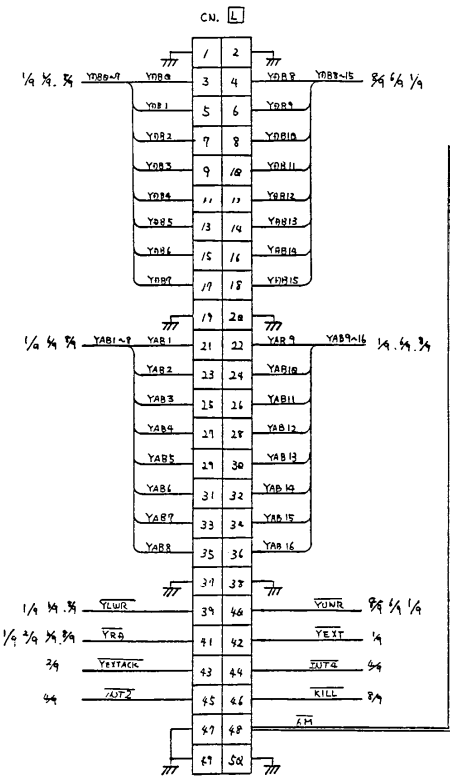
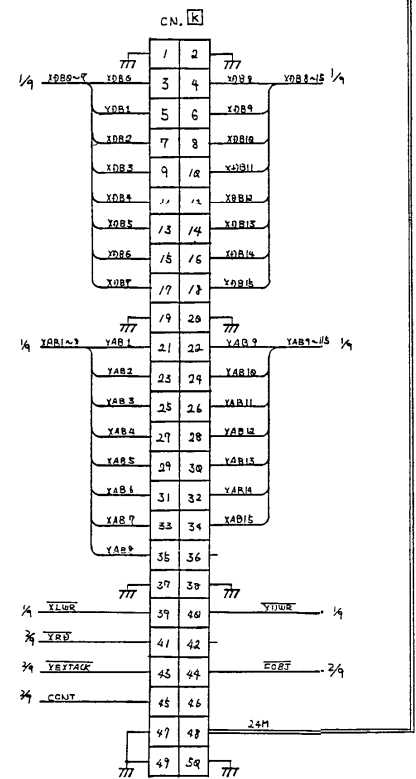
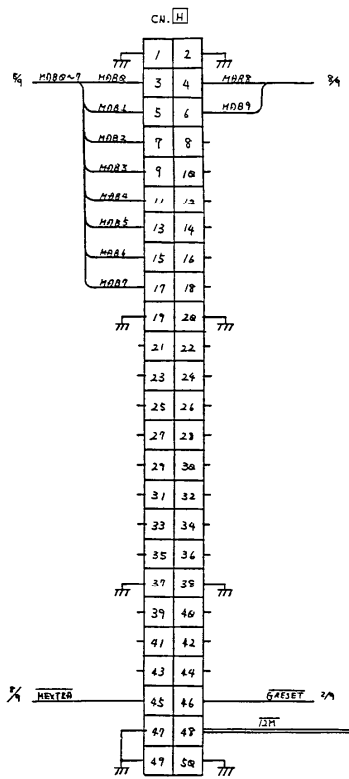
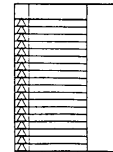

二重線ハダリ短り配線1集

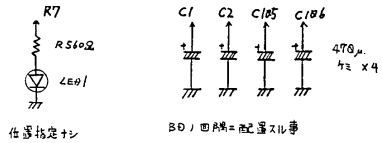

位置指定+シ

BDノ回路=配線シル集

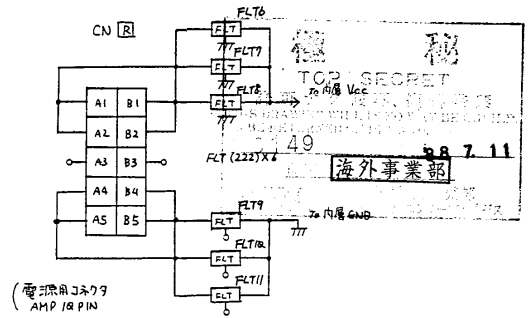

(電源用コネクタ AMP 18 PIN)

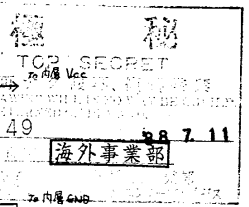

SEGA SEGA ENTERPRISES, LTD.	APR 11 11
THIS DRAWING WILL IN NO WAY BE COPIED. 許可なく複製 TO BE RETURNED ON DEMAND. 複製無断返却	ASSEMBLER 名島
VIDEO BD	REV
GALAXY FORCE	837-6566
DESCRIPTION	PART NO.
171-5810	SHEET 8 OF 8

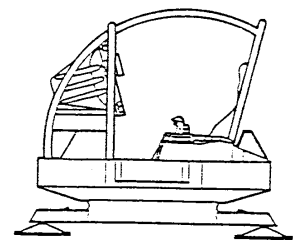
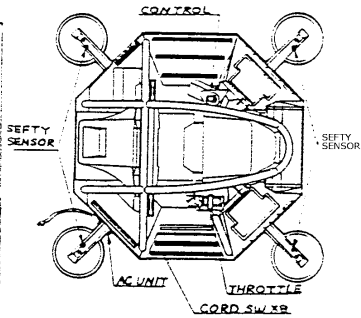
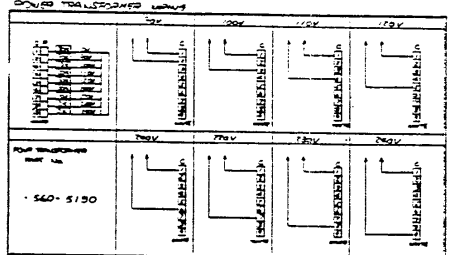
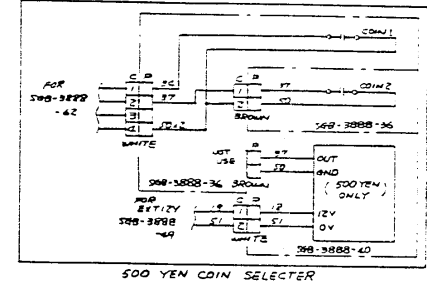
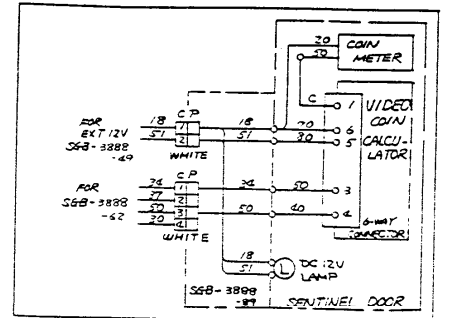
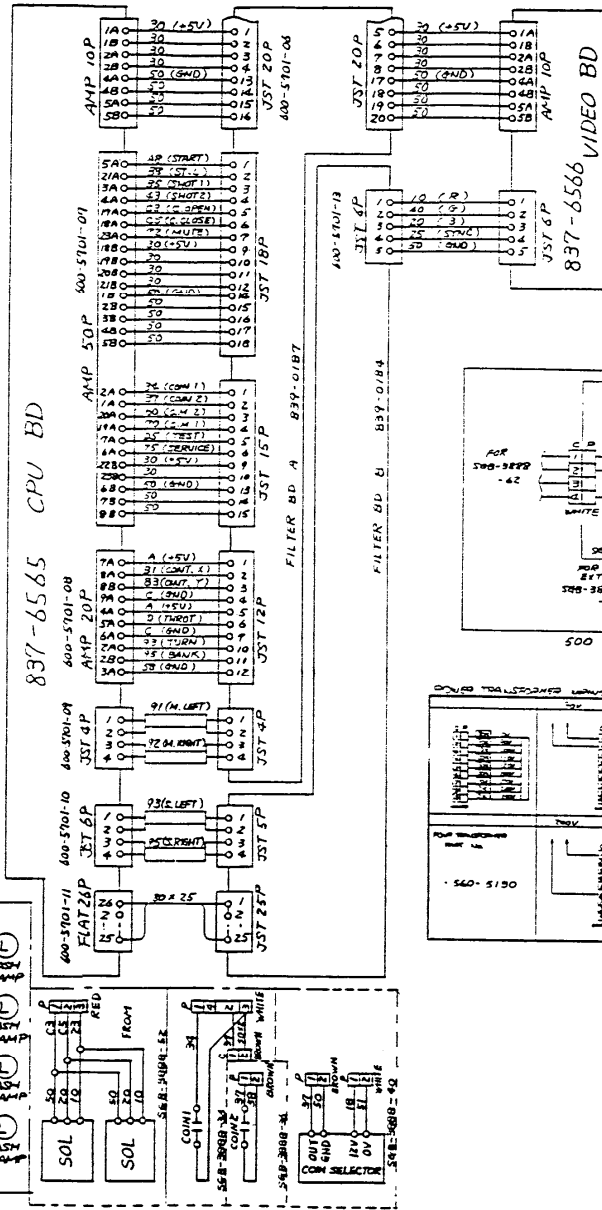
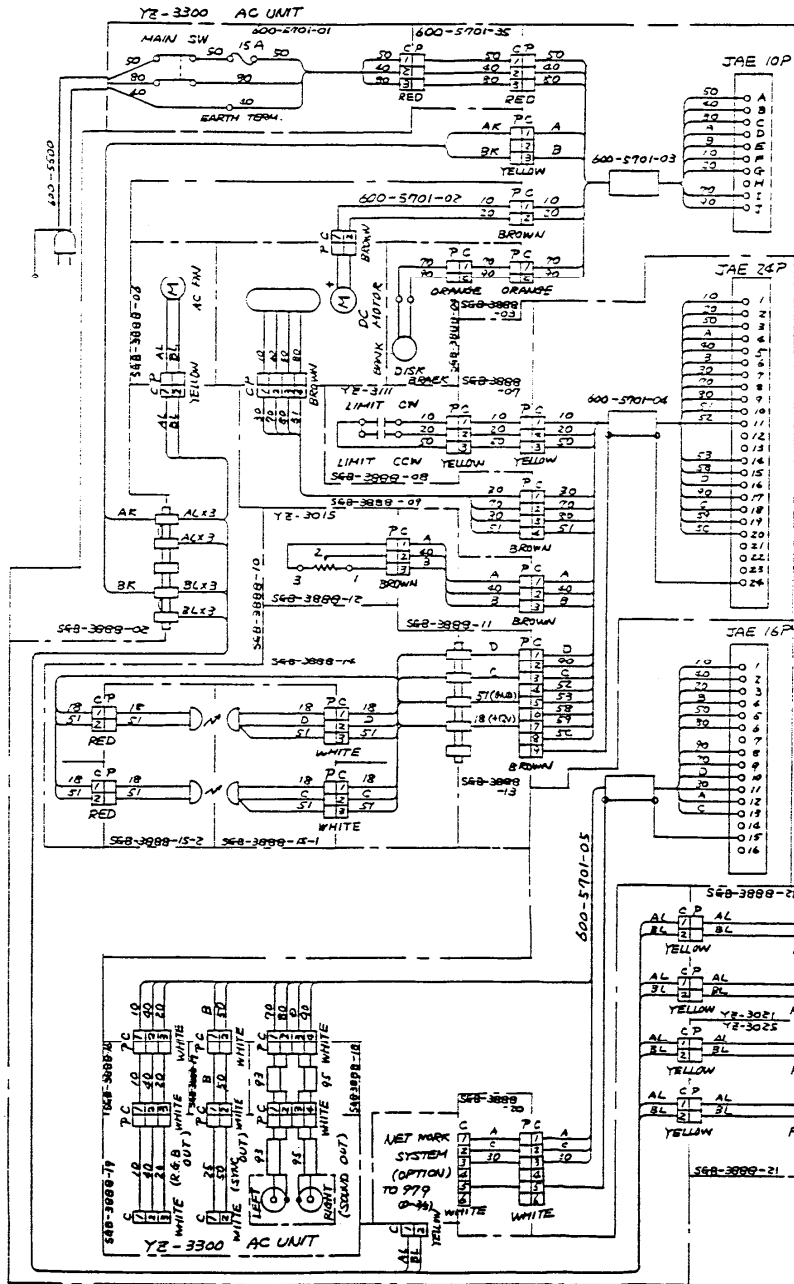

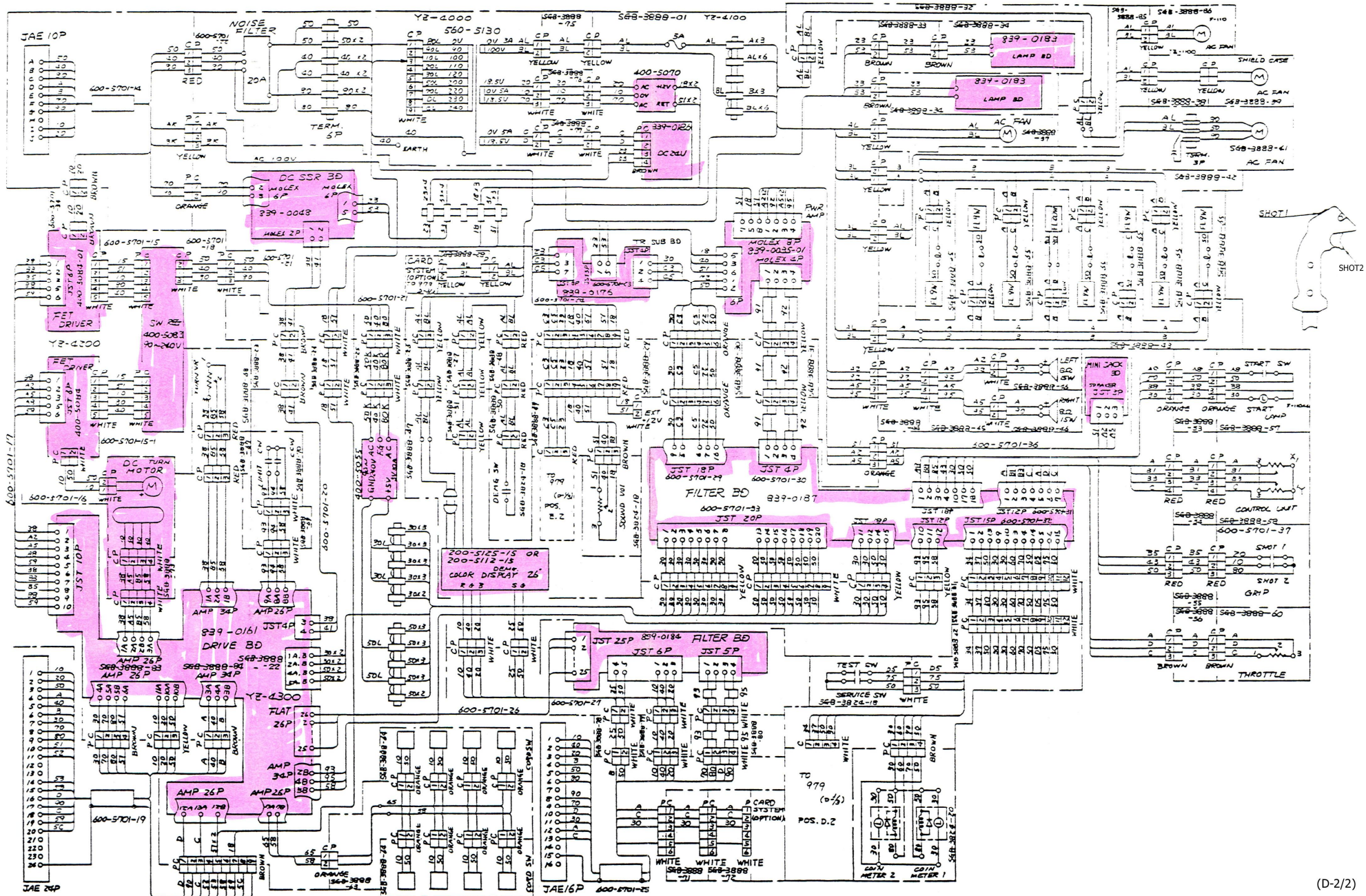



SEGA ENTERPRISES, LTD.  
No. 2-12, Haneda 1-chome  
Ohta-ku, Tokyo 144, Japan  
○ Tel. : (03) 743 - 7438  
○ FAX : (03) 743 - 5539  
○ TLX : J22357 SEGASTAR

© SEGA 1988